

# STANDARD SPECIFICATIONS & DETAILS



Springs Hill Special Utility District  
5510 S. 123 Bypass  
Seguin, TX 78155

(830) 379-7683  
[www.springshill.org](http://www.springshill.org)

NOVEMBER 2024

**Table of Contents**

Introduction.....	3
Impact Fees.....	3
Plan Preparation.....	3
Plan Review.....	3
Mandatory Pre-Construction Meeting.....	4
Final Inspection.....	4
Record Drawings.....	4
System Design and Flow Criteria.....	4
<i>Line Sizing Criteria</i> .....	4
<i>Minimum Line Size</i> .....	5
<i>Water Line Routing</i> .....	5
<i>Depth of Cover</i> .....	5
Fire Protection Standards.....	5
Fire Flow.....	5
Fire Hydrant Location.....	5
Fire Hydrants.....	6
Cross-Connection Control.....	8
Horizontal Separation.....	8
Vertical Separation.....	8
Connection to Existing Water Mains.....	8
Hydrostatic and Leakage Test.....	9
Disinfecting Water Systems.....	9
Water Mains.....	9
Valve Location.....	9
Pipe, Fittings, and Appurtenances.....	10
Non-Standard Pipe Installation.....	10
Pipe Materials.....	10
Dead End Mains.....	11
Ductile Iron Pipe and Fittings.....	11
<i>Fittings</i> .....	11
<i>Mechanical Joints</i> .....	11
<i>Restrained Joints</i> .....	11
<i>Gaskets</i> .....	12
PVC Pipe & Fittings and PVCO Pipe & Fittings (Ultra Blue).....	12
<i>Tracer Wire</i> .....	12
<i>Water Pipe</i> .....	12
<i>Fittings</i> .....	13
<i>Joints</i> .....	13
<i>Restrained Joints</i> .....	13

Valves .....	14
<i>Gate Valves</i> .....	14
<i>Pressure Regulator Valves (PRV)</i> .....	14
<i>PRV Vaults</i> .....	14
<i>Tapping Valves</i> .....	15
<i>Tapping Sleeves</i> .....	15
<i>Service Saddles</i> .....	15
<i>Air Release Valve Assembly</i> .....	15
<i>Valve Box</i> .....	15
<i>Valve Location</i> .....	16
Services .....	16
<i>Installation</i> .....	16
<i>Main Connection to Ductile Iron Cement Pipe</i> .....	16
<i>Service Run</i> .....	16
<i>Service Sleeves</i> .....	16
<i>Meter Boxes</i> .....	17
Trench Excavation, Pipe Cutting and Laying, and Backfilling .....	17
<i>Trench Excavation</i> .....	17
<i>Trenching Requirements</i> .....	17
<i>Dewatering</i> .....	18
<i>Pipe Laying</i> .....	19
<i>Laying PVC and PVCO Pipe</i> .....	19
<i>Laying DICL Pipe</i> .....	19
<i>Backfill, Bedding and Compaction</i> .....	19
SHSUD General Notes .....	21

## Introduction

Construction of domestic water pipelines and appurtenances are subject to inspection and approval by Springs Hill Water Supply Corporation (SHSUD) and shall be in accordance with the requirements of this document and SHSUD's Standard Drawings. Items not specifically referred to herein shall comply with the latest edition of the Standards of the American Water Works Association and shall be subject to approval by SHSUD. Construction methods, material and disposal of products shall also be subject to current standards established by the Texas Commission on Environmental Quality (TCEQ) and any other local, state or federal agencies having authority in their respective jurisdictions.

## Impact Fees

The Texas Legislature has defined "impact fees" as a charge or assessment imposed by a political subdivision against new development in order to generate revenue for funding or recouping the costs of capital improvements or facility expansion necessitated by and attributable to the new development.

## Plan Preparation

All water distribution systems, water main extensions, and all appurtenant items shall be designed in accordance with these standards, SHSUD Standard Details and TCEQ Title 30 Chapter 290 Standards, whichever is most stringent. Consult SHSUD for clarification of specific items.

SHSUD shall own and maintain all portions of the water system up to and including the water meter. The water distribution system or water main extension or any portion thereof, which is to become the property and sole responsibility of SHSUD, shall be designed to be constructed within any public rights-of-way and/or easement.

## Plan Review

For subdivision or site development, the Developer or Customer shall submit 3 complete full size sets of plans, including on-site and off-site improvements, and irrigation plans for review and comment by the SHSUD Engineers. Building plans are not needed. Once plans have been reviewed and approved by SHSUD, the plans shall be stamped by SHSUD as "Approved for Construction." Two sets of these plans will be returned to the customer and one retained by SHSUD for our records. The "Approved for Construction" plans must be always on site during construction.

Any changes to the plans during construction must be documented. Minor changes may be reviewed and approved on site by a representative of SHSUD and the changes annotated on the As-built plans. All major changes shall be submitted in writing to SHSUD for formal review and approval. Determination as to whether or not a formal submittal is required shall be determined on a case by case basis by SHSUD personnel.

After plans are approved and construction is complete, the Developer's Engineer of Record will stamp the plans as "Record Drawings" for submission to SHSUD. One full size paper copy of the As-built drawings shall be submitted along with a CD containing .pdf formatted files of the drawings. Compliance with this submittal requirement is not complete until final review and approval by SHSUD.

### Mandatory Pre-Construction Meeting

One week prior to commencing work, the Contractor shall conduct a pre-construction meeting with SHSUD, at the SHSUD main office. The purpose of the Pre-Construction meeting is to review project status and coordinate scheduled activities.

### Final Inspection

SHSUD will require a final inspection on all main line construction projects. SHSUD will verify operation of valves, hydrants and services. Meter boxes, valve boxes and vaults, must be set to grade and work site must be free of debris, excess material, etc. Bacteriological test samples must have returned from the designated lab free from coliform bacteria and meet the same standards as the source water. This must be noted on the SHSUD acceptance form by a Water Quality Technician. Inspector will then provide three acceptance forms to be signed by the Engineer, Contractor and SHSUD inspector. Each company will receive a dated copy of the form and approved set of drawings and the 1 year warranty will start from the date on that form.

### Record Drawings

Within (14 days) of project completion the contractor shall supply SHSUD with a digital base file in \*.dgn, \*.dwg, or \*.dxf format. This file shall contain points and a description of all the installed fire hydrants, valves, and meter connections for the project. This file shall be referenced to the Texas South Central State Plane (NAD83, survey feet) projection, and elevation data shall be referenced to the NAV88 (feet) datum. Grid coordinates are recommended for the alignment with the City of Seguin GIS Data. The contractor shall indicate whether the file is in a Grid or Surface coordinate system.

Within (14 days) of project completion the contractor shall furnish the Design Engineering Firm with a copy of the full set of drawings that has field revisions made by the Owner or Contractor Approved changes. Upon completion of these changes the Design Engineering Firm shall furnish SHSUD with a complete set of drawings signed by a Licensed Engineer and labeled as Record Drawings or As-Built Drawings on a CD in a PDF format.

SHSUD will not accept responsibility of the infrastructure until they have received a digital base file showing all the installed fire hydrants, valves, and meter connections for the project and a complete set of Record Drawings or As-Built Drawings.

### System Design and Flow Criteria

#### *Line Sizing Criteria*

The pipe sizing design criteria for water distribution systems shall as a minimum provide for at least 100% of the combined maximum day demand rate plus fire flow. The allowable minimum service pressure under said design condition shall not be less than 20 psi (fire flow conditions) or 35 psi at the highest elevation served within the scope of the Project (peak or 1.5 times the average day conditions) in a transmission or distribution line. The current TCEQ minimum flow requirement per EDU shall be met as well. (0.6 GPM per EDU) Transmission lines shall be sized to

allow for a maximum flow of 3ft per second and distribution lines shall be sized for a maximum flow of 5 feet per second.

Over sizing may be required in certain areas based on the SHSUD Water Master Plan. Over sizing determination shall be made by SHSUD.

#### *Minimum Line Size*

The minimum pipe size for distribution mains shall be 2 inches, with the exception that the minimum size for distribution mains serving fire hydrants and fire hydrant branches shall be a minimum of 6 inches in diameter.

#### *Water Line Routing*

Water Lines for the water distribution system for a residential or commercial subdivision shall be routed outside road rights-of-way, within a 15-foot utility easement that is dedicated to SHSUD (exclusive or non-exclusive) unless otherwise approved. With SHSUD approval, water lines may be routed 3' - 5' within a public right-of-way. Multiple points of connection may be required in order to minimize service outage during emergencies, repairs, etc., and to improve fire protection and water quality. Mains shall be looped whenever possible, when looping is not feasible auto flush valves must be installed at dead-ends

#### *Depth of Cover*

Cover as measured from finished grade to top of the pipeline shall be a minimum of 30 inches for pipe diameters up to and including 12 inches. Depth of cover for pipes 14 inches or greater in diameter shall be a minimum of 36 inches. Exceptions must be approved by SHSUD.

#### Fire Protection Standards

Guadalupe County has adopted the International Fire Code (IFC 2006) as its recognized Fire Code Standard. All commercial facilities must be designed to meet the requirements of the IFC 2006 or latest revision. In cases where County Fire Marshall requirements contradict the guidelines listed below, the more stringent of the requirements shall apply.

#### Fire Flow

Fire flow requirements shall be calculated in accordance with the fire flow requirements specified by Insurance Services Office (ISO) based on population, density, and hazardous features of the proposed construction as well as from the City Fire Marshal and County Fire Marshals. The minimum residual pressure at peak hour, maximum day demand condition, plus fire demand shall not be less than 20 psi in each respected pressure zone.

#### Fire Hydrant Location

Hydrants shall typically be located within one foot of the side lot lines, between adjacent properties in residential areas, or in front of commercial and industrial properties as required.

Hydrants shall be a minimum of 2 feet from edge of rights-of-way or curb in areas without sidewalks and shall not obstruct sidewalks.

The location of new fire hydrants shall be identified with a blue reflective pavement marker installed on the roadway. The reflective marker shall be located perpendicular to the hydrant, in the center of the lane closest to the hydrant.

### Fire Hydrants

Fire Hydrants shall be in accordance with Standard No. WA- 21 in the Standard Details.

All fire hydrants shall be Dry Barrel, Traffic Model (break-away), Post Type having Compression Type Main Valves with 5 1/4" or 6" opening, closing with line pressure.

SHSUD reserves the right to limit purchases of fire hydrants to traffic models equipped with safety flange on the hydrant barrel and stem, manufactured by the following manufacturers providing such products conform to the provisions contained herein:

- American-Darling Valve and Manufacturing Company (American-Darling 6-inch B-84-B)
- Clow Valve Company (Clow Medallion)

All fire hydrants shall be provided with one Hydra-Storz adapter (HYST-5.0-4.5NH-NS) with stainless steel butterfly vanes to functionally open waterflow.

#### A. Applicable Specifications

AWWA C-502 current: "AWWA Standard for Dry-Barrel Fire Hydrants".

NFPA 1963: "Standard for Fire Hose Connections".

ANSI A-21.11 current: "American National Standard for Rubber Gasket Joints for Cast Iron and Ductile Iron Pressure Pipe and Fittings".

#### B. Functional Requirements

Design Working Pressure shall be 200 psi and a test pressure of 400 psi for Muller and 250 psi for Clow Fire hydrants.

Inlet shall be side connection hub end for mechanical joint (ANSI A-21.11-current) and shall be rigidly designed to prevent breakage.

Lower Barrel shall be rigid to assure above ground break at traffic feature. Bury length of hydrant shall be four (4) feet minimum, five (5) feet maximum (hydrant lead pipe may be elbowed up from main using restrained joints; flanged joints in lead pipes are not allowed). Flange type connections between hydrant shoe, barrel sections and bonnet shall have minimum of 6 corrosion resistant bolts. Barrel shall have an inside diameter of not less than 7 inches. Hydrant shall have non-rising stem.

Hydrant main valve shall be 5 ¼-inch or 6-inch inside diameter. Valve stem design shall meet requirements of AWWA C502, with Operating Nut turning clockwise to close. Operating Nut shall be pentagonal, 1 ½-inch point to flat at base, and 1-7/16 inches at top and 1-inch minimum height. Seat ring shall be bronze (bronze to bronze threading) and shall be removable with light weight stem wrench. Valve mechanisms shall be flushed with each operation of valve; there shall be a minimum of two (2) drain ports.

Traffic Feature shall have replaceable breakaway ferrous metal stem coupling held to stem by readily removable type 302 or 304 stainless steel fastenings. Breakaway flange or frangible lugs shall be designed to assure aboveground break. Breakaway or frangible bolts will not be acceptable.

Outlet Nozzles shall be located approximately 18 inches above ground. Each hydrant shall have two (2) 2 ½-inch nozzles 180 degrees apart with National (American) Standard Fire Hose Coupling Screw Thread NFPA 1963 and one (1) 5-inch Harrington Integral Hydrant Storz Nozzle, Harrington, Inc. model "HIHS" or equivalent (approved by SHSUD engineer). Nozzles shall be threaded or cam-locked, O-ring sealed, and shall have type 302 or 304 stainless steel locking devices. Nozzle caps (without chains) and cap gaskets shall be furnished on the hydrant. The cap nut shall have the same configuration as the operating nut, with exception to the Storz Cap, which shall not have a pentagon-operating nut and shall be attached by cable to the hydrant.

Hydrants shall be Dry-Top Construction, factory lubricated oil or grease with the lubricant plug readily accessible.

Hydrant shall have double O-ring seals in a bronze stem sheath housing to assure separation of lubricant from water and shall have a weather cap or seal, or both, as approved by the Owner, to provide complete weather protection.

Install one inline gate valve at each side of tee that connects to the fire hydrant assembly to water main.

### C. Material Requirements

All below ground bolts shall be corrosion resistant. The hydrant valve shall be Neoprene, 90 durometers minimum. The seat ring, drain ring, operating nut and nozzles shall be bronze, AWWA C-502 current, containing not over 16 percent zinc. Break-away stem coupling shall be of ferrous material; its retaining pins, bolts, nuts, etc. of type 302 or 304 stainless steel.

Coatings shall be durable and applied to clean surfaces. Exterior surfaces above ground shall receive a coating of Sherwin Williams' silver metallic paint or approved equal. The coating shall be applied according to coating manufacturer's specifications. Other exposed ferrous metal shall receive asphalt-based varnish, or approved equal, applied according to the coating manufacturer's specifications.

Hydrants shall be installed at locations shown on the drawings. If one or more hydrants cannot be installed as shown because of obstructions, driveways, or changes, new locations shall be requested of SHSUD or the Fire Department having jurisdiction.



Each hydrant shall stand plumb, with nozzles and pumper connections horizontal facing the street. The hydrant shall be placed so the flange joining the upper and lower sections of the barrel shall be at least 3 inches but not more than 6 inches above the finished line of the curb or grade. The interior of the hydrant shall be thoroughly inspected and cleaned of all foreign matter before being set in place.

#### Cross-Connection Control

Backflow prevention devices shall be installed on all lines where the possibility exists for water from any other source to enter the public water supply system.

All fire lines serving commercial and industrial facilities, all water lines serving properties with more than one source of water or a possible cross-connection as determined by a SHSUD inspector, and all commercial irrigation lines shall be metered and equipped with appropriate backflow preventers. Alternative installations will need to be approved by SHSUD.

#### Horizontal Separation

Water mains shall be installed to provide a minimum horizontal separation of 9 feet (per TCEQ regulations) from any existing or proposed wastewater line (gravity or force main). The distance shall be measured from outside of pipe to outside of pipe. In cases where it is not practical to maintain the 9-foot minimum separation an alternative may be submitted to SHSUD for consideration and approval. Separation to all other facilities including gas, telephone, storm and electric shall be a minimum of 5 feet. *Joint trenches of water with electrical, telecom or cable lines are not permitted.*

#### Vertical Separation

Water mains crossing other pipelines shall be laid to provide a minimum vertical distance of 18 inches between the outside of the water main and the outside of the storm water, reclaimed water, wastewater line, conduit, or other facility. This shall be the case where the water main is either above or below the other pipelines. Water main crossings below other pipelines or conduits should be avoided whenever possible. At crossings, one full length of water pipe shall be located so both joints will be as far from the other pipelines as possible. All water lines crossing wastewater lines shall follow 30 TAC Chapter 290 Subchapter D §290.44(e) thru §290.44(e)(5) whichever may be applicable. Natural or propane gas lines shall be encased in concrete which shall extend 12" above and below the gas line and shall have a minimum separation of 18" from outside of pipe to outside of pipe.

#### Connection to Existing Water Mains

All connections to existing water mains shall be made under the direct supervision of SHSUD.

Water mains shall be tapped in such a manner as to avoid disturbance or disruption to the operation of the main in service and to protect the potable water supply from contamination.

Valves on existing mains shall only be operated by SHSUD personnel.

The Contractor shall be responsible for properly backfilling the work area pit after the work is completed.

When service must be interrupted to existing customers during construction of a tap or addition of appurtenances the Contractor shall provide 3-day notice to SHSUD.

#### Hydrostatic and Leakage Test

Water mains shall be tested as a whole or in sections between valves. The total length of pipe for any single test shall not exceed 2,000 feet. The mains shall be tested in accordance with Section 4, Hydrostatic Testing, AWWA C600 (latest revision) under an average hydrostatic pressure of not less than 150 psi, when installing C909 Class 200 300 psi gauge, for a minimum of 4 hours. When installing C909 Class 150 testing shall be not less than 150 psi using a 300-psi gauge for 30 minutes. All valves shall be tested for secure closure.

All pumps, gauges and measuring devices shall be furnished, installed, and operated by the Contractor and all such equipment and devices and their installation, shall be approved by SHSUD. All water for testing and flushing shall be potable water provided by SHSUD, at the Contractor's expense.

All restrained sections of the buried main shall be completely backfilled before such sections are tested. The entire pressure and leakage process shall be done in the presence of a SHSUD Inspector.

When leakage occurs in excess of the specified amount, defective pipe, pipe joints or other appurtenances shall be located and repaired at the expense of the Contractor. If the defective portions cannot be located, the Contractor, at his own expense, shall remove and reconstruct as much of the original work as necessary to obtain a water main within the allowable leakage limits upon retesting.

#### Disinfecting Water Systems

The Contractor shall disinfect all pipe and fittings installed in the system and receive the required approvals and clearances prior to placing the system in service. The disinfection shall be accomplished in accordance with the applicable provisions of AWWA C 651-99, "Disinfecting Water Mains," and all appropriate approval agencies. Care shall be taken to provide disinfection of the entire system. After disinfection, the Contractor will thoroughly flush the line until water samples show a chlorine content equal to or greater than existing system and no less than 0.20 MGL and bacteriological tests are satisfactory.

#### Water Mains

All Water Mains and associated appurtenances shall be constructed in accordance with current SHSUD Standard Details.

#### Valve Location

Inline valves shall be placed so that the maximum allowable length of water main required to be shut down for repair work shall be minimized as determined by SHSUD. The maximum spacing shall be

1,000 feet at each hydrant or fire service unless approved by SHSUD. Unless within the City of Seguin or New Braunfels. Fire Marshals will determine the distances.

#### Pipe, Fittings, and Appurtenances

All 4-inch pipe shall be either polyvinyl chloride (PVC) or ductile iron cement lined (DICL) pipe; Pipe sizes 6 inches through 12 inches shall be either molecularly oriented PVC or DICL pipe; pipes larger than 12 inches shall be determined on a case-by-case basis. Pipe larger than 24-inches in diameter shall be approved on a case-by-case basis. All pipes on bridges, under railroad tracks, crossing residential streets and cul-de-sacs shall be DICL or follow each representing firms' specifications. All lines requiring casing shall be constructed in accordance with the SHSUD Standard Detail for casing. Any deviation from this standard shall be subject to review and approval by SHSUD.

#### Non-Standard Pipe Installation

When indicated on the Drawings or acceptable to Engineer or designated representative, concrete encasement shall be placed to protect the pipe. Pipe or bedding shall not be placed where:

- (a) the top of the pipe would have less than 36 inches of cover,
- (b) the ground water invades the trench, or
- (c) the trench bottom is of unstable material.

If either of these conditions is encountered, the Engineer or designated representative shall be notified and may direct the Contractor to:

- (a) encase the pipe with concrete,
- (b) change pipe material, or
- (c) use a higher strength class of pipe.

Concrete encasement shall extend from 6 inches below to 6 inches above the outer projections of the pipe over the entire width of the trench in accordance with Standard Detail WA-2," Concrete Encasement".

#### Pipe Materials

The following table lists the allowable pipe materials for various sizes of potable water main pipe unless otherwise approved:

Water Main Pipe		
Diameter	Material	General Specification
4"	PVC	SDR-21 ASTM D-2241 Class 200
6" to 12"	PVC or DICL	AWWA C909 Class 200 (Ultra Blue) *
4" to 24"	DICL	ANSI/AWWA A 21.51/C151 Class 350

\*C909 Class 150 Pipe may be approved on a case-by-case basis

### Dead End Mains

The designing of systems with dead end mains shall be avoided to the maximum extent possible. If a dead-end main is necessary, an auto flush hydrant must be installed at the end of the line. See standard details for an example of an auto flush hydrant.

### Ductile Iron Pipe and Fittings

Pipe shall have an exterior bituminous coating in accordance with ANSI A21.51. Pipe interior shall have a cement mortar lining with an asphaltic seal coat conforming to ANSI/AWWA A21.4/C104.

### *Fittings*

All ductile fittings shall be mechanical joint with a minimum pressure rating of 350 psi and shall conform to the requirements of ANSI/AWWA A21.10/C110 or A21.53/C153. All fittings shall be coated and lined as specified above for ductile iron pipe.

### *Mechanical Joints*

Mechanical joints consisting of bell, socket, gland, gasket, bolt, and nuts shall conform to ANSI A21.11.

### *Restrained Joints*

Restrained joints shall be installed at all valve fittings and locations as required by SHSUD. All tee's, cross's and elbows must have a concrete thrust block support. The concrete must be poured with adequate containment in place to avoid loss of concrete from under and at the point of thrust on the fitting. The use of rocks, bricks, and dry bagged cement are not considered as adequate thrust blocking and are not permitted.

The length of pipe to be restrained shall be calculated as required, and subject to review and approval by SHSUD staff. SHSUD recommends using a free software package from [www.ebaa.com](http://www.ebaa.com) as a starting point for determining restraint calculations. Where minimum restrained length is not met,

thrust blocks shall be used in addition to restrained pipe. Calculations must be shown to support drawings.

**Approved Manufacturers and Models (Joint Restraints for DICL):**

Joint Restraint System:	Ductile. Iron	D.I. 16" above
Ford/Uni-Flange	1390C	1390C
EBAA Iron Sales, Inc	1700	1700
Romac Industries	611	470SJ
Star Pipe Products	1100	1100
Sigma Corporation	PVP/PTP/SLDH	SLDH

*Gaskets*

Pipe and fitting gaskets, conforming to ANSI A21.11, shall be made of EPDM (ethylene propylene diene monomer) or SBR (styrene-butadiene rubber). U.S. Pipe Field Lock gaskets or SHSUD approved equivalent shall be used for restraining DICL pipe up to 24".

**PVC Pipe & Fittings and PVCO Pipe & Fittings (Ultra Blue)**

All polyvinyl chloride (PVC) pipe water mains shall have a suitable electronic locator buried over the water main approximately one foot below grade. The tape shall be continuous between valves and secured to each valve. The tape shall be at least 4.5 mils thick, 6-inch minimum width and made with an aluminum material sandwiched between 2 layers of polyethylene. It shall have imprinted in permanent black ink with 1-inch letters "CAUTION WATER MAIN BURIED BELOW" on blue background.

*Tracer Wire*

For all non-metallic pipes within private easements or in cross-country routes, pipe shall be a tracer wire attached to the pipe. See standard details for proper emplacement of tracer wire. All PVC and fittings shall bear the approval seal of the National Sanitation Foundation (NSF) that will remain legible during normal handling, storage, and installation. PIPE COLOR SHALL BE BLUE FOR POTABLE WATER MAINS.

*Water Pipe*

All PVC pipe (6-inch and larger) shall have the same O.D. as ductile iron pipe and be compatible for use with ductile iron fittings C-909.

### *Fittings*

Fittings for PVC pipe (6-inches through 12-inches) shall be ductile iron mechanical joint (MJ Fittings) with a minimum pressure rating of 350 psi and shall conform to the requirements of ANSI/AWWA A21.10/C110 or A21.53/C153.

### *Joints*

PVC pipe shall have provisions for expansion and contraction provided in the joints. All joints shall be designed for push-on makeup connection. A push-on joint may be an elastomeric gasket ball end coupling manufactured as an integral part of the pipe barrel consisting of a thickened section with an expanded bell with a groove to retain a rubber sealing ring of uniform cross-section.

### *Restrained Joints*

All PVC pipe shall be restrained per manufacturer's recommendation.

1. Pipe restraints shall be utilized to prevent movement for push-on D.I. or PVC (C900&C905) (compression type) bell and spigot pipe connections or where a flexible coupling has been used to join two sections of plain end pipe D.I. or PVC (C900&C905). The restrainer may be adapted to connect a plain end D.I. or PVC pipe to a ductile iron mechanical joint (MJ) bell fitting. The restrainer must not be directionally sensitive.

The pipe shall be restrained by a split retainer band. The band shall be cast ductile iron, meeting or exceeding ASTM A536-80, Grade 65-45-12. The inside face or contact surface of the band shall be of sufficient width to incorporate cast or machined non-directionally sensitive serration to grip the outside circumference of the pipe. The serration shall provide full (360 degrees) contact and maintain pipe roundness and avoid any localized points of stress. The split band casting shall be designed to "bottom-out" before clamping bolt forces (110ft-lb minimum torque) can over-stress the pipe and will provide full non-directionally sensitive restraint at the rated pressures.

2. Bolts and nuts used to attach the split retainer ring shall comply with ANSI B 18.2/18.2.2, SAE Grade 5. Tee-bolts, nuts and restraining rods shall be fabricated from high-strength, low-alloy steel per AWWA C111-90.
3. The split ring type non-directionally sensitive restrainer system shall be capable of a test pressure twice the maximum sustained working pressure of the specified pipe.
4. Restraint systems sizes six through twelve inches shall be capable of use for both ductile iron and/or PVC C900.
5. The restraint system may consist of two types: the two split retainer rings and for new construction use only the one split and one solid cast backup ring.

**Approved Manufacturers and Models (Joint Restraints for PVC):**

Joint Restraint System:	PVC C-900/C905
Ford/Uni-Flange	1390C
EBAA Iron Sales, Inc	1500
Romac Industries	611
Star Pipe Products	1100
Sigma Corporation	PVP/PTP

**Valves***Gate Valves*

Valves shall typically be AFC or Clow Company gate valves. Underground gate valves shall be of the resilient seat type meeting the requirements of AWWA C509 and coated per AWWA C550 as manufactured by the American Darling or Clow Company. These valves shall have non-rising stems, shall be furnished with 2-inch square AWWA operating nuts, and shall open when the nut is turned counterclockwise. Valves shall have mechanical joint ends and shall be furnished complete with joint accessories. Exposed or above-ground gate valves shall be outside screw and yoke (OS&Y) flanged joint type.

*Pressure Regulator Valves (PRV)*

SHSUD requires PRV's to be installed with oil filled pressure gauges on both sides of the PRV to record incoming flow pressure and outgoing flow pressure. Steel braided lines from PRV to regulator must be installed on the pilot system. The PRV is to be installed as a bypass of the main and can be one standard size smaller than the main. All main line PRV's shall have an additional PRV bypass for low flows. The bypass can be as much as 2 standard sizes smaller than the main line PRV. Gate valves with a 2" operating nut must be installed in order to isolate PRV on main line and PRV on the bypass. PRV's shall be approved by SHSUD.

*PRV Vaults*

Vaults need to be constructed of concrete or steel with double spring-loaded skid resistant steel doors. Vaults are sized in order to house PRV, bypass and gate valves. Vaults need to be set 2" above finished grade - but should not exceed 6" above finished grade without SHSUD Engineering staff approval. Each end of the vault shall have a circular opening 2" larger in diameter than the PRV to allow for pipe penetration. These openings shall be sealed with cement slurry upon insertion of the piping. The vault floor shall consist of 6" to 8" of washed

rock with 2” clearance under all valves. This same washed rock will serve as the foundation and the bottom 18” of backfill for the vault.

### *Tapping Valves*

Tapping valves shall be mechanical joint outlet, non-rising stem, resilient seat gate valves meeting the applicable requirements of AWWA C509 and C550. Tapping valves shall be specifically designed for pressure tapping with sufficient seat opening to allow full diameter taps to be made.

### *Tapping Sleeves*

Tapping sleeves for size-on-size connections shall be mechanical joint split cast iron units and rated for 200 psi working pressure. For less than size-on-size connections, tapping sleeves shall be fabricated steel units with a fusion-bonded epoxy coating and shall be pressure rated as above. The Contractor shall determine the outside diameter of the existing main before ordering the sleeve. Tapping sleeves shall have an outlet flange per ANSI B16.1.

### *Service Saddles*

Service saddles shall have a brass body and be suitable for either wet or dry installation. The sealing gasket shall be the O-ring type suitable for the applicable service. Outlet flange shall be ANSI B16.1.

### *Air Release Valve Assembly*

Air release valves shall be of the type that will release air from the line when pressurized and keep air from entering the line when not pressurized. Air release valves shall be located at high elevation points on the pipeline and operate automatically. Air release valves shall be ½” Apco #55 or equivalent subject to approval by SHSUD. Larger air valves may be required for mains 12” and larger. Air release valves shall be housed in an 18”x24” or larger concrete meter box with a cast iron ring and lid with the word WATER cast into the lid.

### *Valve Box*

Valve boxes for all valves installed below ground shall consist of a PVC riser, and a cast iron “Lincoln Hat” box and lid. They shall be designed so as to prevent the transmission of surface loads directly to the valve or piping. Valve box extensions shall be installed to reserve a minimum of 50% of the adjustment for a future extension.

The operating nut should not exceed 36 inches below finished grade. However, if conditions require that the operating nut exceeds 36 inches, then an extension, mechanically attached to the valve, shall be added, and the top of the extension shall not exceed 12 inches below finished grade.



### *Valve Location*

Inline valves shall be placed so that the maximum allowable length of water main required to be shut down for repair work shall be minimized as determined by SHSUD. The maximum spacing shall be 1000 feet and at each hydrant or fire service. All SHSUD cross-country main line valves will have a 2" x 54" marker post installed 12" behind the valve box, buried and concreted into place 18" deep and painted blue. The 2" marker pipe must be filled with concrete.

### *Services*

Service Installation shall include the complete installation from the connection at the main to the meter. The Contractor shall furnish all labor and material required to install the services. The meter will be furnished and installed in accordance with customer membership as shown per the tariff by SHSUD.

### *Installation*

Service Installation shall be made in accordance with the latest revision of SHSUD's Standard Details for the appropriate service connections. All materials shall be as indicated on the detail drawings.

### *Main Connection to Ductile Iron Cement Pipe*

A minimum amount of cement coating shall be removed from cement coated main prior to applying the service clamp or the welded coupling as designated in the Standard Details. When placing a service clamp on wrapped pipe the coating is not to be removed. Care shall be exercised to avoid tearing or scuffing of pipe coating.

### *Service Run*

Service lines from the main shall have a minimum cover of 30 inches from the final grade. The service pipe shall first make a 90-degree angle bend upwards for connection to the angle meter stop. The angle meter stop shall be installed in a vertical position with the outlet horizontal to the grade and perpendicular to a curb line.

### *Service Sleeves*

SHSUD will require water service lines to be sleeved, if these lines are to cross any public or private roadways. A 2-inch sleeve would be used for a 1-inch water service. Service sleeves that will carry larger than 1-inch service lines must be 4-inch or as approved by SHSUD prior to the start of main line construction. Services must be sleeved a minimum of 5-foot past the edge of pavement or face of curb. Service sleeve casing shall be per Standard No. WA-35.

*Meter Boxes*

Meter boxes shall have Automatic Meter Reading Accessibilities (AMR), be set square and level 1-inch above the finished grade of the surrounding area to avoid run-off water. They shall be in a line parallel to and 6-inch from the back of the curb or sidewalk. Where no curb or sidewalk exists, the meter boxes shall be set at the location indicated on the drawings or as directed by the SHSUD; meter boxes will be placed at property lines in most cases. **Meter boxes will not be placed within a driveway, or within any paved area.** The boxes, rectangular in shape, shall be set with the long side perpendicular to the center line of the street or rights-of-way, with the notched end toward customer piping.

*Trench Excavation, Pipe Cutting and Laying, and Backfilling*

Bedding of all Water Mains shall adhere to the Standard Bedding details based on both current and proposed usage of the area above the pipe, whichever is more stringent.

*Trench Excavation*

All excavations shall be open cut, with banks of trenches kept as nearly vertical as possible. Water mains may be offset to one side of a trench but a minimum of 8" clearance must be maintained between the trench wall and the watermain.

*Trenching Requirements*

The trench floor shall provide a uniform bearing for each full length of pipe section. Excavate bell holes after the trench has been graded. Perform all excavations of whatever substance encountered to the depths shown or indicated on the drawings. Pipe shall be bedded with a minimum of 6-inch of the same  $\frac{3}{4}$  to dust bedding material or approved screened excavated material. Trench walls should be near vertical even when working in an area that is sloped. When appropriate SHSUD will allow cut or fill techniques to be used to level an area for excavation.

*Standard Bedding Material*

Pipe Material	Cement Stabilized Backfill	Natural or Manufactured Sand	Pea Gravel	Pipe Bedding Stone	
				Uncrushed Gravel	Stone Screenings
Welded Steel	X				
Service Tubing $\frac{3}{4}$ " to 2-1/2"		X	X		X
Up to 15 Inch ID		X	X	X	X

Larger Than 15 Inch ID			X	X	
------------------------	--	--	---	---	--

1. General requirements and limitations governing bedding selection.

- a) Crushed gravel or crushed stone shall not be used.
- b) Uncrushed gravel may be used with polyethylene film wrap in trenches up to 6 feet deep and in deeper trenches where ample trench width, a tremmie, or conditions will allow controlled placement of the gravel without damaging the polyethylene wrap.
- c) Pea Gravel or bedding stone shall be used in blasted trenches.

2. Requirements to prevent particle migration.

Bedding material shall be compatible with the materials in the trench bottom, walls and backfill so that particle migration from, into or through the bedding is minimized. The Edwards Aquifer may require one or more of the following measures to minimize particle migration: use of impervious cut-off collars; selected bedding materials, such as pea gravel or bedding stone mixed with sand; filter fabric envelopment of the bedding; cement stabilized backfill; or other approved materials or methods. Measures to minimize particle migration will be shown on the Drawings or designated by the E/A, and, unless provisions for payment are provided in the contract documents, the cost of these measures shall be agreed by change order. The following limitations shall apply.

- (a) Sand, alone, shall not be used in watercourses, in trenches where groundwater is present, or in trenches with grades greater than 5 percent.
- (b) Pea gravel or bedding stone, alone, shall not be used in the street right-of-way within 5 feet of subgrade elevation in trenches that are 3 feet or wider.
- (c) Each gravel or bedding stone, alone, shall not be used where the trench bottom, sides, or backfill is composed of non-cementitious, silty, or sandy soils having plasticity indices less than 20, as determined by the E/A.

*Dewatering*

The Contractor shall provide and always maintain during construction ample means and devices to promptly remove and dispose of all water from any source entering trench excavations or other parts of the work.

Dewatering shall be performed by methods that will maintain a dry excavation, preservation of the final lines and grades and to protect all utilities. If flooding of the trench does occur, the Contractor shall immediately dewater and restore the trench. Damage or altered pipeline appurtenances or trench materials shall be repaired as directed by SHSUD. Water will be disposed in such a manner as will not cause injury to public or private property, nor is a

menace to the public. Other methods of water control, other than dewatering, shall be subject to the approval of SHSUD.

### *Pipe Laying*

Pipe shall be constructed of materials specified and as shown on the drawings. Each section of pipe shall rest upon the pipe bed for the full-length barrel, with recesses excavated to accommodate bells and joints. Any pipe which has a grade or joint disturbed after lying shall be taken up and re-laid. No pipe shall be laid when the trench conditions or the weather is unsuitable for such work, except by permission of SHSUD. Any section of pipe already laid which is found to be defective or damaged shall be replaced with new pipe without additional cost to SHSUD. Excavation, trenching and backfilling shall be in accordance with the requirements of the applicable portions of these specifications.

### *Laying PVC and PVCO Pipe*

All PVC pipe shall be installed in accordance with standards set forth in the UNIBELL “Handbook of PVC pipe design and construction” unless such standards conflict with this manual in which case this manual shall apply.

### *Laying DICL Pipe*

All DICL pipe shall be installed in accordance with standards set forth in the DIPRA “Installation Guide for Ductile Iron Pipe” unless such standards conflict with this manual in which case this manual shall apply. Contractor shall cut pipe only as necessary to comply with alignment shown on the drawings.

### *Backfill, Bedding and Compaction*

Backfill shall not be placed until the pipeline has been inspected by SHSUD. Backfill material shall not be dropped directly upon the pipeline. The backfill material shall be deposited from one end of the trench uniformly on both sides of the pipe. Minimum 8” bedding below water mains and a minimum 12” cover over the top of water mains.

When, in the opinion of SHSUD, material excavated from the trench is unsuitable backfill or when it is required by the jurisdictional agency, suitable backfill shall be furnished and placed by the Contractor. Screening of excavated trench material for bedding may be allowed using a 1-inch or 1 ¼-inch screen under no circumstance will rocks larger than 2” be allowed in bedding.

Backfill for hand tamping shall be deposited in layers not to exceed 4-inch thickness and for mechanical tamping not to exceed 6inch. Care shall be taken not to injure the pipe while ensuring thorough consolidation. Where appropriate, excess material shall be heaped over the trench to allow for settlement.

At locations outside of streets, backfill of selected material from the ground surface to the depth of one foot shall be compacted to produce compaction equal to or greater than that of the original ground, or to

produce no less than 85% relative compaction. The Contractor will perform both field and laboratory test and inspection as required by SHSUD.

All streets are to be restored to their original condition with at least the same amount of properly compacted sub grade and pavement.

All unsuitable material and excess backfill shall be removed and disposed of by the Contractor concurrently with the installation of the main.

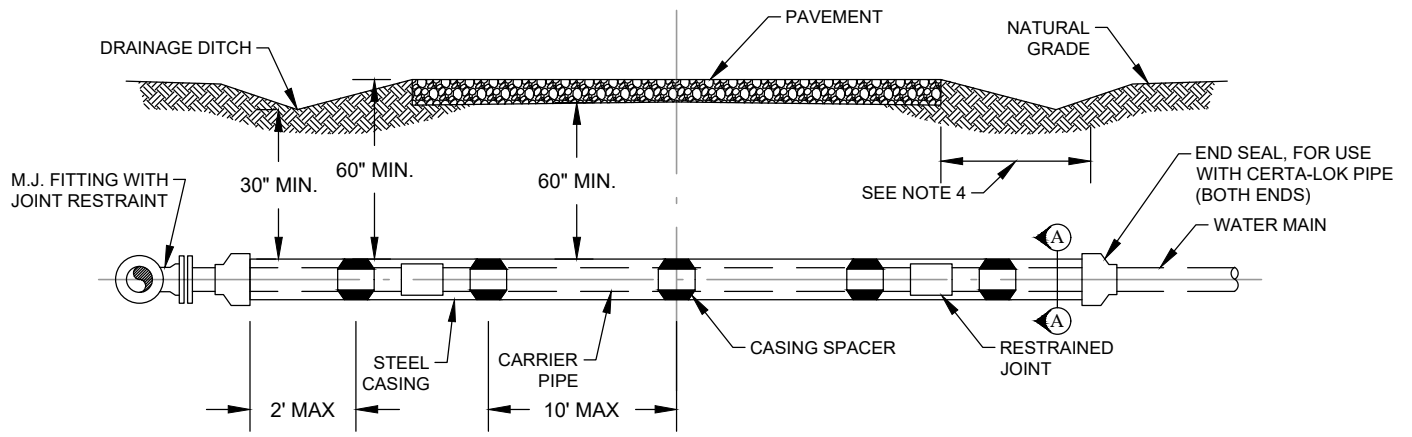

NOT TO SCALE

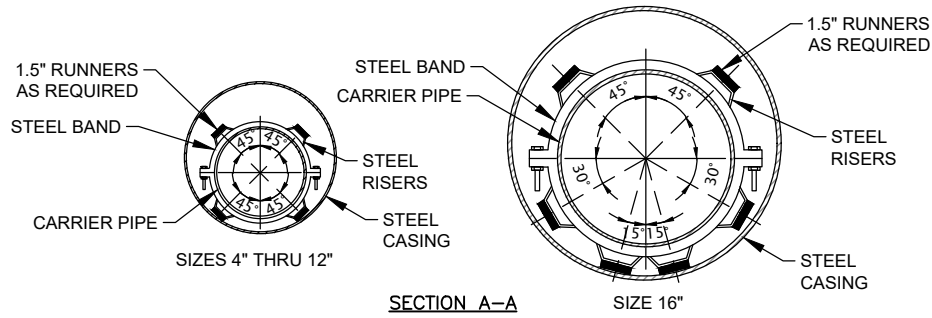

CARRIER PIPE			STEEL CASING					CASING SPACERS	
NOMINAL SIZE (IN)	PIPE OUTSIDE DIAMETER (IN)	RESTRAINT OUTSIDE DIA. (IN)	MIN. NOMINAL SIZE(IN)	OUTSIDE DIAMETER (IN)	INSIDE DIAMETER (IN)	WALL THICKNESS (IN)	WEIGHT CLASS	BAND WIDTH	No. OF RUNNERS PER TIE
4	4.80	9.25	10	10.750	10.25	0.25	STANDARD	8"	2 TOP, 2 BOTTOM
6	6.90	11.25	12	12.750	12.250	0.375	STANDARD	8"	2 TOP, 2 BOTTOM
8	9.05	14.75	16	16.000	13.150	0.375	STANDARD	8"	2 TOP, 2 BOTTOM
12	13.20	16.90	20	20.000	19.150	0.375	STANDARD	8"	2 TOP, 2 BOTTOM
16	17.40	25.51	30	30.000	29.250	0.375	STANDARD	8"	2 TOP, 4 BOTTOM

NOTES:

- CARRIER PIPE SIZES ARE BASED ON CERTA-LOK C900/RJ FOR 4" TO 12" PIPE DIAMETER AND CERTA-LOK C905/RJ FOR 14" TO 24" PIPE DIAMETER.
- STEEL CASING SHALL BE STANDARD WEIGHT OR HEAVIER PIPE CONFORMING TO ASTM A-36, ASTM A-568, ASTM A-135, ASTM A-139 OR OTHER ACCEPTABLE STANDARD SPECIFICATION. PIPE SHALL BE COATED AND LINED IN ACCORDANCE WITH AWWA C-210 OR APPROVED EQUAL. PIPE JOINTS SHALL BE WELDED IN ACCORDANCE WITH AWWA C-206. STEEL CASING SHALL BE NEW OR USED IN GOOD CONDITION ACCEPTABLE TO SPRINGS HILL WATER SUPPLY CORPORATION AND TO THE ROADWAY AUTHORITY.
- SUBSEQUENT CASING SPACERS ARE REQUIRED FOR 4" TO 14" PIPE SIZES TO BE AT 10 FEET APART AND FOR 16" TO 30" PIPE SIZES TO BE AT 8 FEET APART WITHIN THE CASING WITH AT LEAST 3 SPACERS PER JOINT ON PIPE. ONE CASING SPACER SHALL BE REPLACED WITHIN 2 FEET OF ENDS OF CASING FOR ALL PIPE SIZES.
- CASING PIPE SHALL EXTEND A MINIMUM OF 10 FT. PAST EDGE OF PAVEMENT ALONG TXDOT ROADWAYS AND A MINIMUM OF 5 FT. PAST EDGE OF PAVEMENT ALONG ALL OTHER ROADWAYS UNLESS OTHERWISE DIRECTED BY ENGINEER OR REGULATORY AUTHORITY.
- CASING SPACERS SHALL BE MADE FROM T-304 STEEL OF A MINIMUM 14 GAUGE THICKNESS.
- CASING SPACERS SHALL HAVE A SYNTHETIC RUBBER OR PVC LINER TO INSULATE THE PIPELINE FROM THE SPACER.
- CASING SPACERS SHALL HAVE A 1.5" WIDE GLASS REINFORCED PLASTIC OR UHMW POLYMER RUNNERS TO INSULATE THE SPACER FROM THE CASING

**SPRINGS HILL SPECIAL UTILITY DISTRICT**

**CASING DETAIL**

DATE:  
03/03/2010

REVISIONS:  
07/22/2021

STANDARD NO.  
WA-1

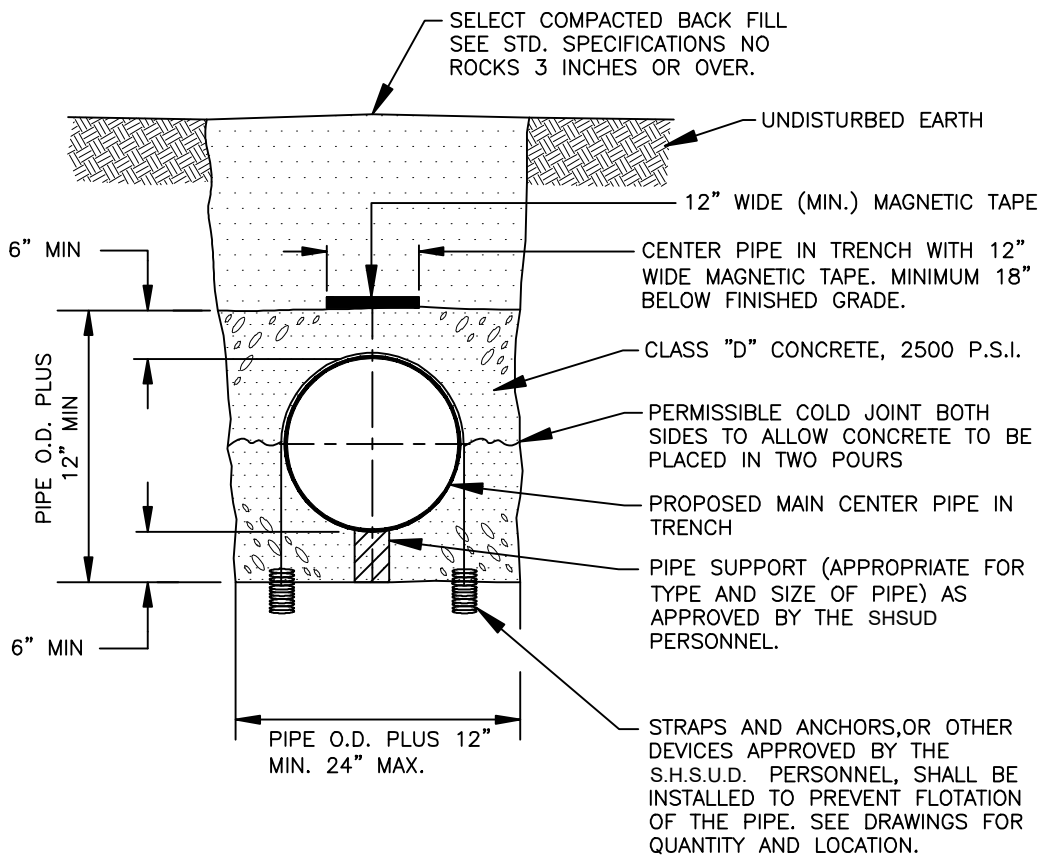

**SPRINGS HILL SPECIAL UTILITY DISTRICT**

**CONCRETE ENCASEMENT**

DATE:  
03/03/2010

REVISIONS:

STANDARD NO.  
WA-2

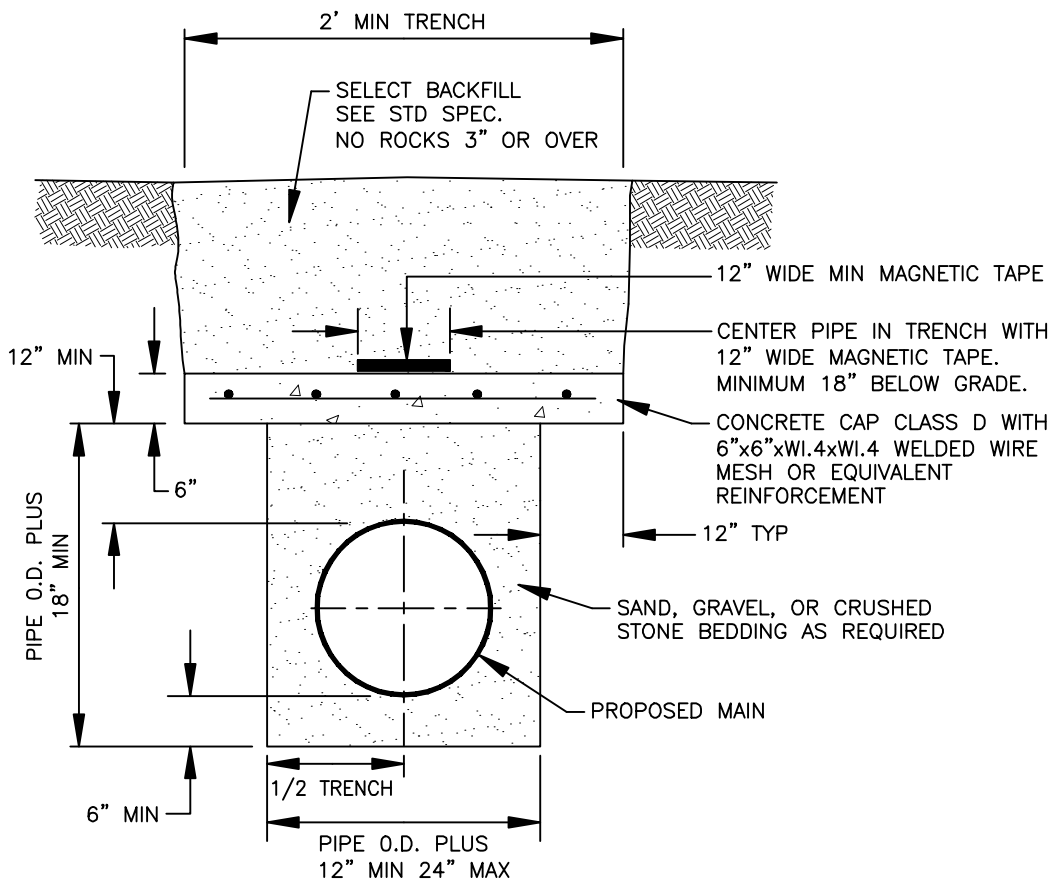

**SPRINGS HILL SPECIAL UTILITY DISTRICT**

**CONCRETE TRENCH CAP**

DATE:  
07/23/2010

REVISIONS:

STANDARD NO.  
WA-3



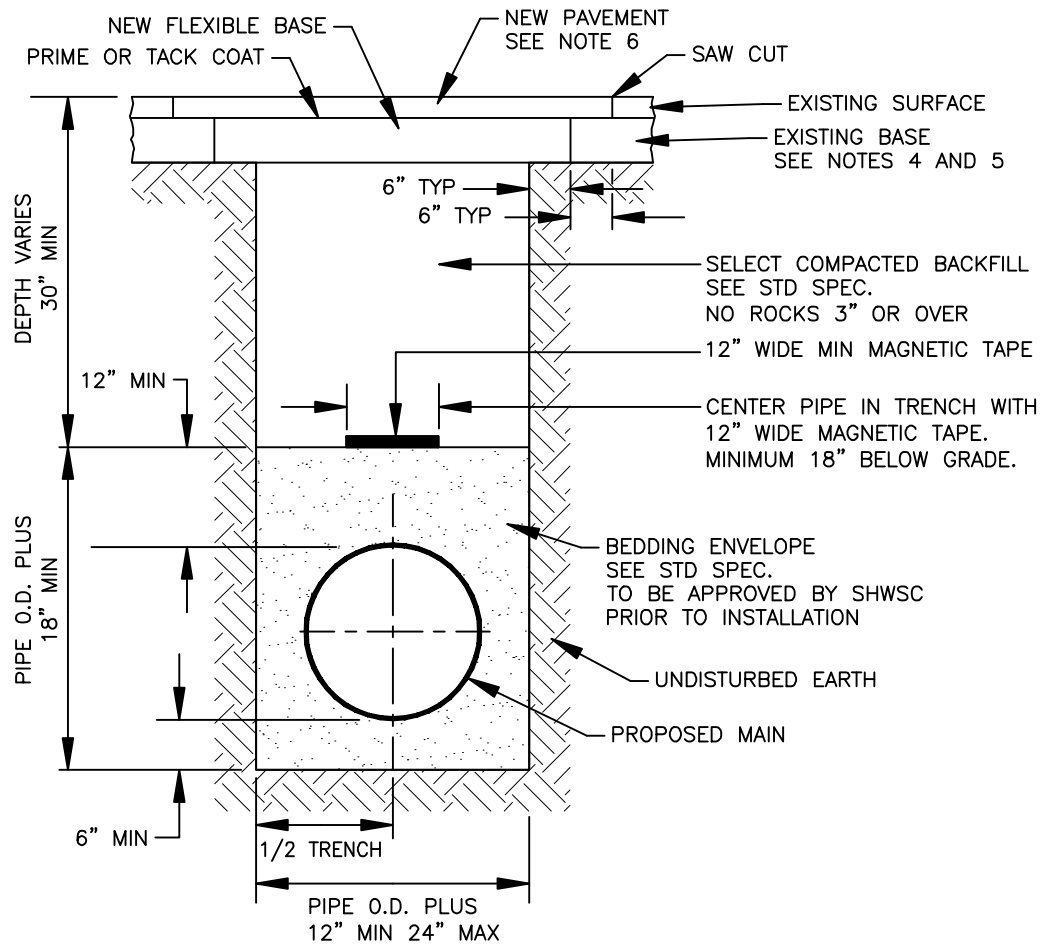

NOTES:

1. THE EXISTING PAVING SURFACE SHALL BE SAW CUT IN A STRAIGHT LINE, A MINIMUM OF 12 INCHES WIDER THAN THE UNDISTURBED SIDES OF THE TRENCH, SYMMETRICAL ABOUT THE CENTERLINE OF THE EXCAVATION.
2. ANY CONCRETE PAVING SHALL BE CUT 6 INCHES WIDER THAN THE UNDISTURBED SIDES OF THE EXCAVATION.
3. IF EXCAVATION AREA IS OPEN FOR TEMPORARY PUBLIC USE, THE SURFACE SHALL BE MAINTAINED LEVEL WITH ADJACENT RIDING SURFACE WITH COLD MIX OR TEMPORARY HOT MIX ASPHALTIC CONCRETE.
4. ROAD BASE AND SURFACE MATERIALS IN THE TRENCH CUT SHALL BE REPLACED IN KIND, OF EQUAL THICKNESS, OR WITH MINIMUM BASE THICKNESS OF 10 INCHES WHICHEVER IS GREATER.
5. ALL DAMAGED AREAS OF PAVEMENT OUTSIDE THE TRENCH CUT AREA SHALL BE REMOVED AND REPLACED WITH MINIMUM OF 8 INCHES OF BASE OR MATCH EXISTING, WHICHEVER IS GREATER.
6. SURFACE PAVEMENT SHALL BE OF THE KIND AND THICKNESS AS EXISTING, OR MINIMUM 2 INCHES, WHICHEVER IS GREATER.
7. ALL WATER LINES SHALL HAVE A MINIMUM PRESSURE CLASS OF 200 PSI.

**SPRINGS HILL SPECIAL UTILITY DISTRICT**

**TRENCH WITH PAVED SURFACE**

DATE:  
07/26/2010

REVISIONS:

STANDARD NO.  
WA-4

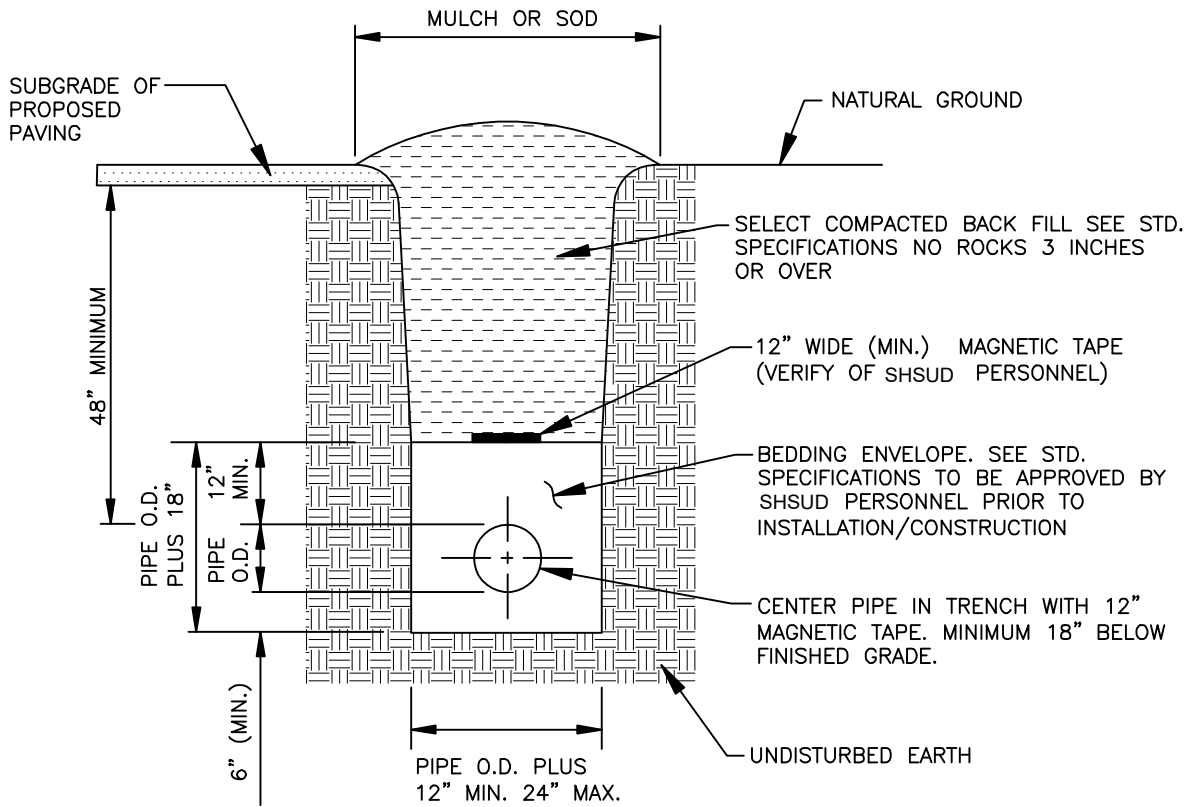

NOTES:

1. ALL WATER LINES SHALL HAVE A MINIMUM PRESSURE CLASS OF 200 P.S.I.
2. BEDDING AND BACKFILL SHALL BE COMPACTED TO 90% STANDARD PROCTOR

**SPRINGS HILL SPECIAL UTILITY DISTRICT**

**TRENCH WITH UNFINISHED SURFACE**

DATE:  
03/03/2010

REVISIONS:

STANDARD NO.  
WA-5

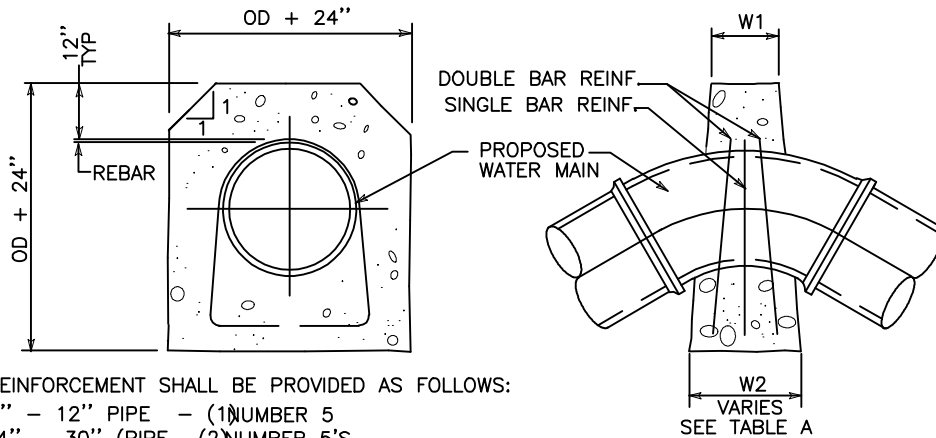

REINFORCEMENT SHALL BE PROVIDED AS FOLLOWS:  
 6" - 12" PIPE - (1) NUMBER 5  
 14" - 30" (PIPE - (2) NUMBER 5'S  
 36" - 48" PIPE - (3) NUMBER 7'S

**VERTICAL DOWN BEND**

TABLE A UPWARD THRUST GRAVITY BLOCKS			
PIPE DIA.	MIN. TOP WIDTH W1	ANGLE (degrees)	BOTTOM WIDTH - W2 (in)
6"	6"	0-5	NOTE 2
		5-15	24
		15-25	48
		> 25	NOTE 1
8"	6"	0-5	NOTE 2
		5-9	30
		9-15	36
		> 15	NOTE 1
12"	6"	0-5	NOTE 2
		5-15	48
		> 15	NOTE 1
16"	12"	0-5	NOTE 2
		5-10	60
		10-15	96
		> 15	NOTE 1
24" THRU 36"		> 5.0	NOTE 1
42" THRU 48"		> 3.0	NOTE 1

NOTES:

- FOR ANGLES GREATER THAN THOSE INDICATED RESTRAINT JOINTS SHALL BE INSTALLED
- FOR JOINT DEFLECTIONS LESS THAN 5 DEGREES, NO HORIZONTAL OR VERTICAL THRUST RESTRAINT IS REQUIRED FOR PIPES LESS THAN 42" IN DIAMETER.

THRUST BLOCK DESIGN AS FOLLOWS

- PRESSURE OF 150 P.S.I. (ACTUAL IF HIGHER) + 50 % SURGE ALLOWANCE
- MAXIMUM SOIL BEARING SEE TABLE BELOW

SOIL TYPES	PRESSURE
LOOSE OR SPONGY SOIL	1500 Lb/Sq.Ft.
UNDISTURBED SOIL, CALICHE	2000 Lb/Sq.Ft.
LIMESTONE ROCK	4000 Lb/Sq.Ft.

NOTES:

- THE EARTH BEARING SURFACE SHALL BE UNDISTURBED MATERIAL, IF NOT POSSIBLE, THE FILL BETWEEN THE BEARING SURFACE AND THE UNDISTURBED SOIL MUST BE COMPACTED TO TO A MINIMUM OF 90% STANDARD PROCTOR DENSITY.
- IT SHALL BE THE RESPONSIBILITY OF THE CONTRACTOR TO INSTALL ADEQUATE THRUST BLOCKING. THE CONTRACTOR SHALL MAKE THE DETERMINATION IN THE FIELD AS TO TYPE OF SOIL AND USE THE "THRUST BLOCKING DESIGN" TO ADJUST THE AMOUNTS OF THRUST BLOCKING REQUIRED AT EACH PLACE OF USE.
- ALL FITTINGS SHALL BE BLOCKED REGARDLESS OF THE ANGLE OF DIRECTION.
- ALL JOINTS WITHIN 30' OF BEND MUST BE RESTRAINED.

**SPRINGS HILL SPECIAL UTILITY DISTRICT**

**THRUST BLOCK DETAILS  
SHT 1 OF 2**

DATE:  
03/03/2010

REVISIONS:

STANDARD NO.  
WA-6

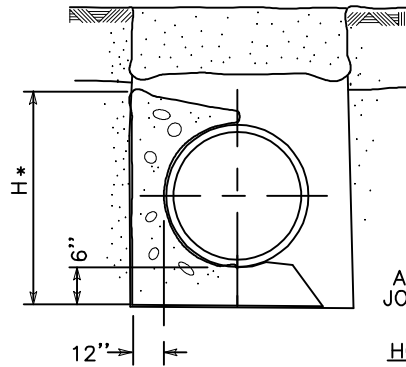

ADEQUATE TO CLEAR  
JOINT AND/OR BOLTS

HORIZONTAL BEND

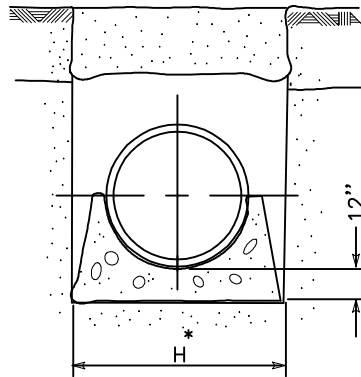
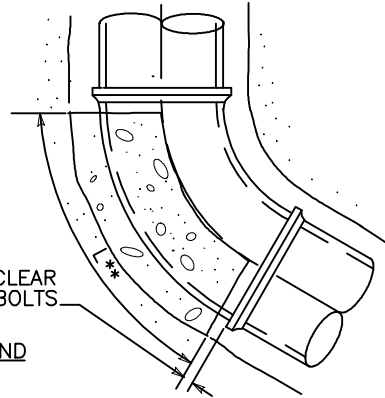

VERTICAL BEND UPWARD

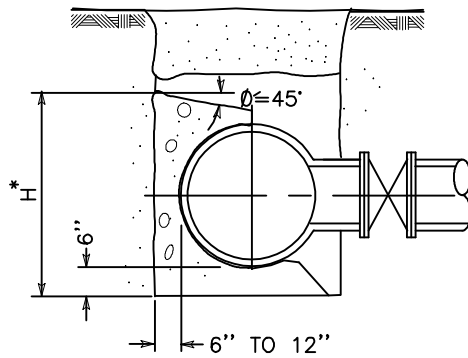
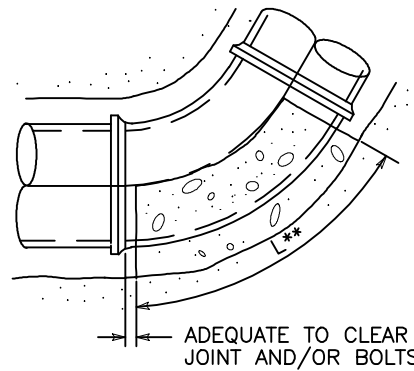

TEE / OUTLET

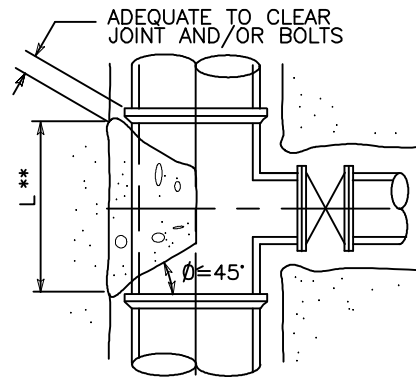

- \* THE DIMENSION FOR "H" MUST BE GREATER THAN DIAMETER OF THE PIPE
- \*\* LENGTH "L" ALONG THE BEND MUST BE GREATER THAN "H" AND LESS THAN 2 TIMES "H"

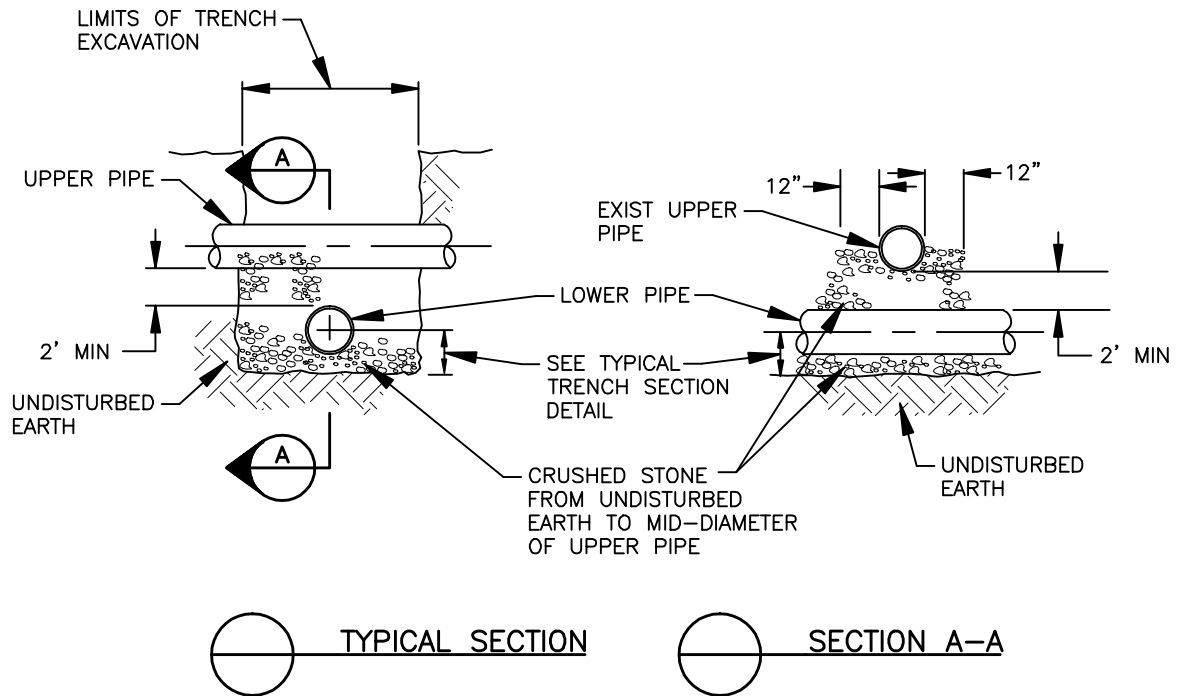

NOTES:

1. T.C.E.Q. RULES AND REGULATIONS ON SANITARY SEWER, STORM SEWER AND WATER MAIN CROSSINGS AND SEPARATIONS SHALL BE STRICTLY ENFORCED, 30 TAC CHAPTER 290, SUBCHAPTER D.
2. ALL OTHER UTILITIES TO MAINTAIN 5 FOOT SEPARATION FROM WATER MAINS AND SERVICES, GAS, ELECTRIC, CABLE (ETC.) TO BE LOCATED OPPOSITE SIDES OF PROPERTY.
3. UTILITY CROSSINGS SEPARATED BY LESS THAN 12 INCHES, PIPES SHALL BE ENCASED WITH 6 INCHES OF CONCRETE ALL AROUND AND CENTERED TO CROSSING FOR A MINIMUM LENGTH OF 20 FEET TOTAL.
4. SPECIFICATIONS, BEDDING MATERIAL MUST BE APPROVED BY AUTHORIZED SHSUD PERSONNEL, BEFORE START OF JOB.
5. AT ANY CREEK CROSSING THE MAIN SHALL BE STEEL ENCASED AND/OR 6" CONCRETE ENCASEMENT TO WITHIN 10 FEET OUTSIDE OF CREEK OR DRAINAGE DITCH AREA.

**SPRINGS HILL SPECIAL UTILITY DISTRICT**

**UTILITY CROSSING**

DATE:  
06/15/2010

REVISIONS:

STANDARD NO.  
WA-7

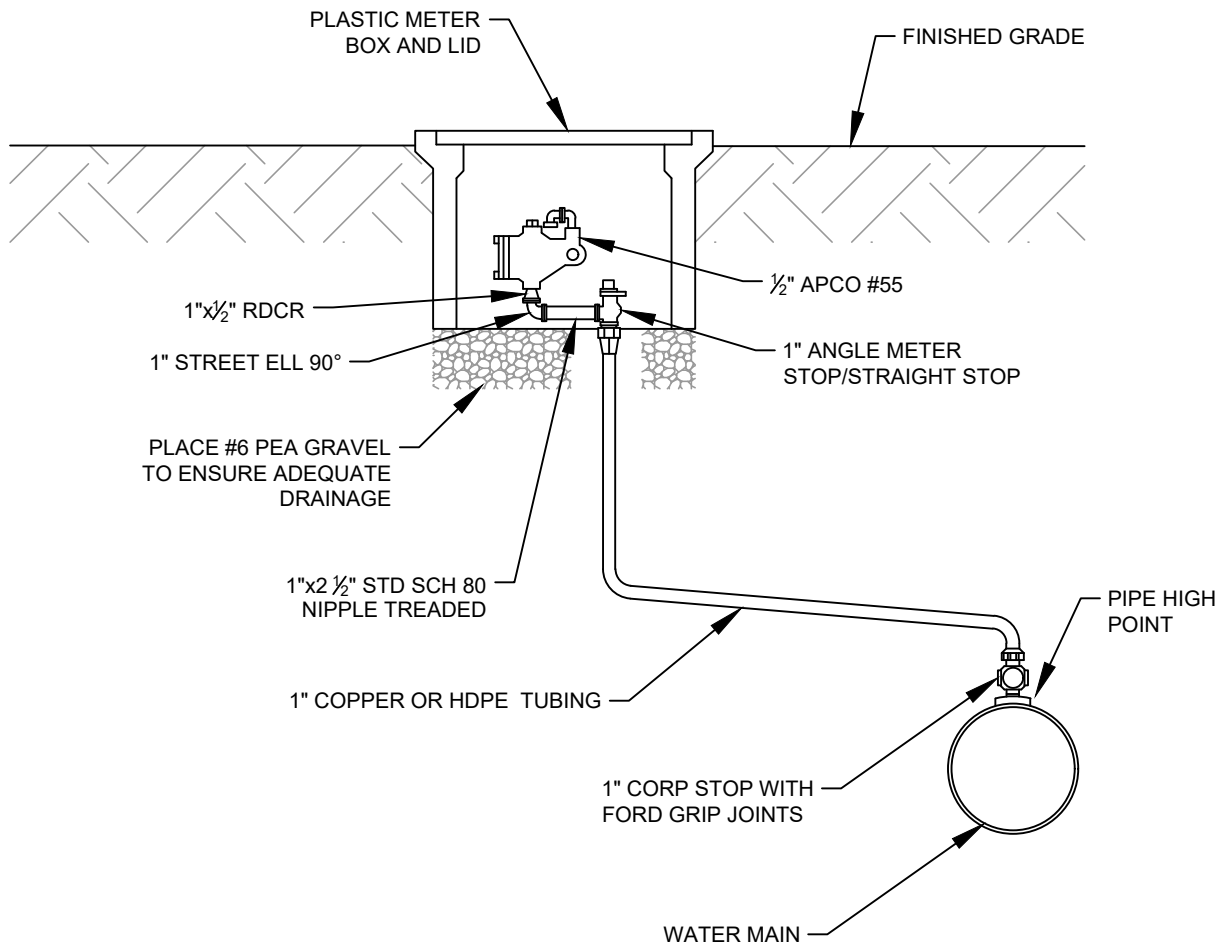

NOTES:

1. ALL CORPS AND ANGLE STOPS TO BE LEFT OPEN.
2. BLOW OFF MAIN BEFORE INSTALLING AIR VALVE.

**SPRINGS HILL SPECIAL UTILITY DISTRICT**

**STANDARD 1/2" AIR RELEASE VALVE INSTALLATION**

DATE:  
07/26/2010

REVISIONS:  
03/15/2022

STANDARD NO.  
WA-8

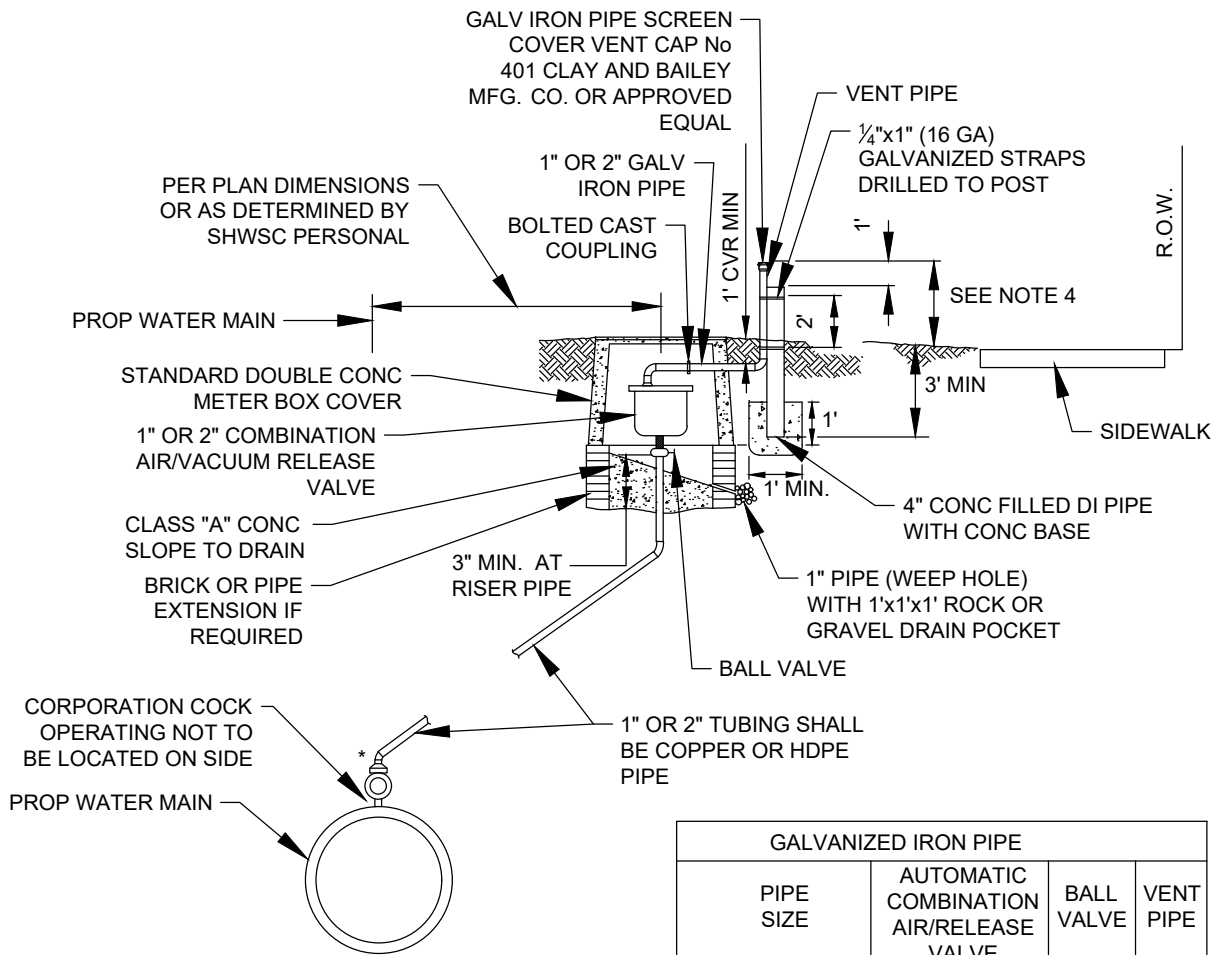

\* THREAD TO COMPRESSION BRASS ELBOW ALLOWED IF NECESSARY DUE TO DEPTH LIMITATIONS.

GALVANIZED IRON PIPE			
PIPE SIZE	AUTOMATIC COMBINATION AIR/RELEASE VALVE	BALL VALVE	VENT PIPE
UP TO 10"	1"	1"	1"
12" AND OVER	2"	2"	2"

**NOTES:**

- EXTERIOR SURFACES OF EXPOSED AIR VENT PIPE AND D.I. SUPPORT PIPE SHALL BE PAINTED WITH RUST-OLEUM ACRYLIC 5225 (SAFETY BLUE), OR EQUAL, PER COATING MANUFACTURER INSTRUCTIONS PRIOR TO INSTALLATION.
- AIR VENT PIPE INSTALLATION SHALL BE AS NEAR AS PRACTICAL TO RIGHT-OF-WAY LINE OR EASEMENT LINE AS INDICATED ON PLANS (VERIFY LOCATION WITH SHSUD PERSONNEL)
- CONCRETE METER BOX PENETRATION SHALL BE CORE BIT DRILLED. VOID SHALL BE FILLED BY PRESS-SEAL GASKET CORP. PSX RESILIENT CONNECTOR MEETING ASTM C923 OR APPROVED EQUAL.
- IN UNDEVELOPED AND DEVELOPED AREAS, THE AIR RELEASE SHALL BE 5 FEET IN HEIGHT SUPPORTED BY 4" STEEL PIPE WHICH HAS BEEN PAINTED BLUE AND FILLED WITH CONCRETE. IN DEVELOPED AREAS THE AIR RELEASE SHALL BE 8" TO 12" IN HEIGHT AND LOCATED NOT TO CONFLICT WITH SIDEWALK.
- AUTOMATIC COMBINATION AIR/VACUUM VALVE SHALL BE INSTALLED IN A MANNER WHICH WILL ALLOW REMOVAL OF ASSEMBLY WITHOUT REMOVAL OF THE CONCRETE METER BOX.

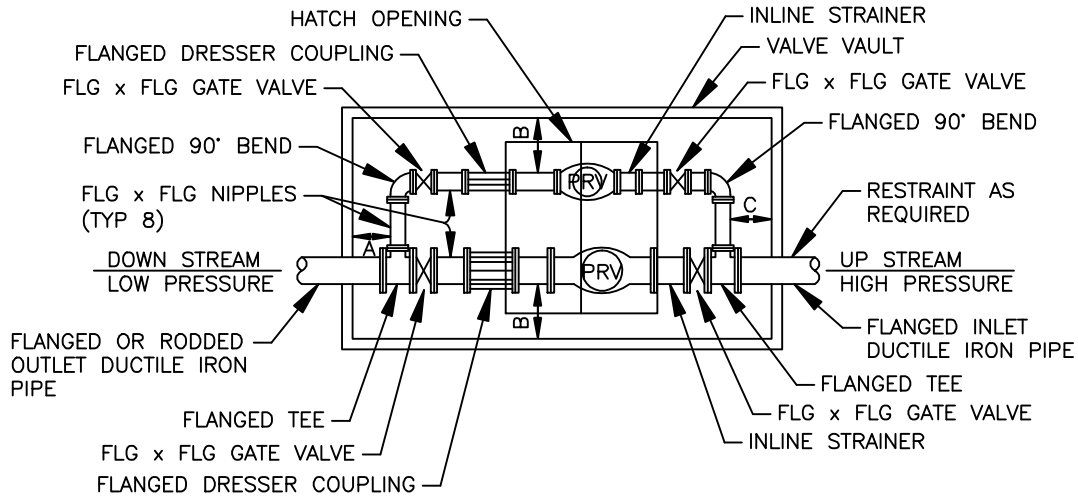

**TOP VIEW**

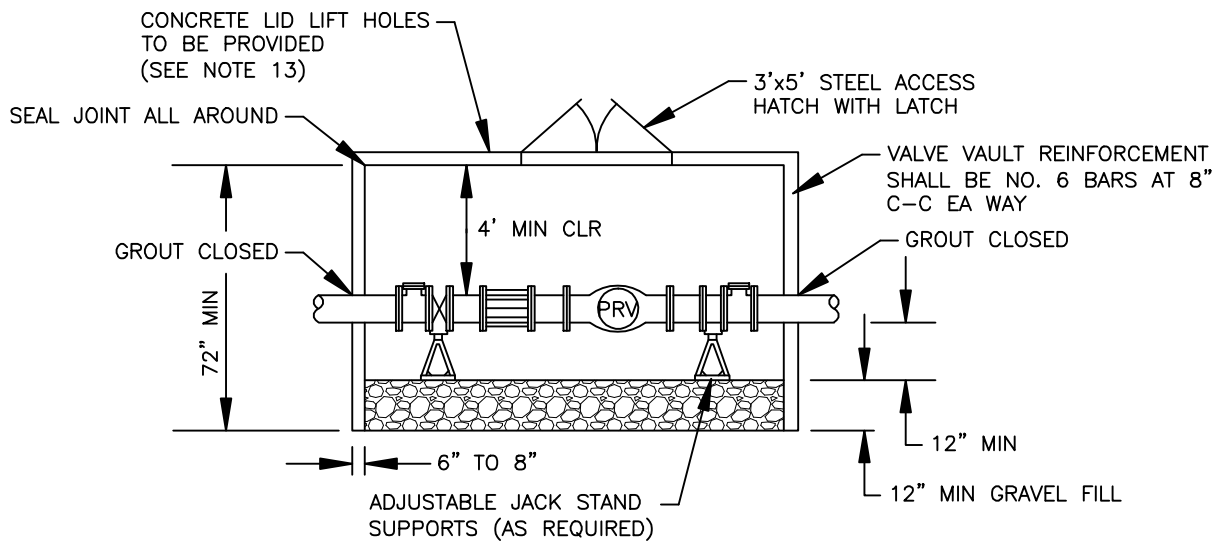

**ELEVATION**

PRV 1	PRV 2
4"	2"
6"	2"
8"	2"
8"	4"
12"	4"



NOTES:

1. ALL PIPE IN PRESSURE REDUCING VALVE/BYPASS INSTALLATION TO BE THREADED BRAS OR FLANGED DUCTILE IRON OR CAST IRON PIPE.
2. PRESSURE REDUCER VALVE SHALL BE IN ACCORDANCE WITH SHSUD STANDARDS.
3. LID SHALL BE FLUSH WITH NATURAL GROUND.
4. IF VALVE IS NOT ATTACHED TO FLANGE FITTING, ALL FITTINGS WILL BE MEGA LUGGED RETAINED GLANDS OR APPROVED EQUIVALENT.
5. PROVIDE THE ALTITUDE/ELEVATION AND THE PRESSURE ON THE LOW SIDE OF THE PRV TO SHSUD
6. VERTICAL GATE VALVES TO BE WHEEL OPERATED.
7. ALL SLEEVES TO BE ON THE DOWN STREAM SIDE FOR SAFETY PURPOSES.
8. ALL UPSTREAM OR HIGH PRESSURE MATERIALS TO BE FLANGED.
9. ALL NON-FLANGED PIPE TO BE INSTALLED WITH MEGA LUG RETAINER GLAND OR APPROVED EQUIVALENT.
10. ALL VALVES WILL HAVE JACK STAND SUPPORT.
11. ALL POINTS "A" THROUGH "C" SHALL HAVE A MINIMUM CLEARANCE OF 18 INCHES.
12. UPSTREAM PIPE SHOULD BE RODDED FOR ADDED SAFETY TO GUARD AGAINST BLOW OFF.
13. IN UNDEVELOPED AREAS, TOP OF VAULT SHALL BE SET FLUSH WITH THE NATURAL GROUND. IN DEVELOPED AREAS, TOP OF VAULT SHALL BE SET FLUSH WITH SURROUNDING AREA.

**SPRINGS HILL SPECIAL UTILITY DISTRICT**

**DUAL PRV INSTALLATION  
SHEET 2 OF 2**

DATE:  
07/26/2010

REVISIONS:

STANDARD NO.  
WA-10

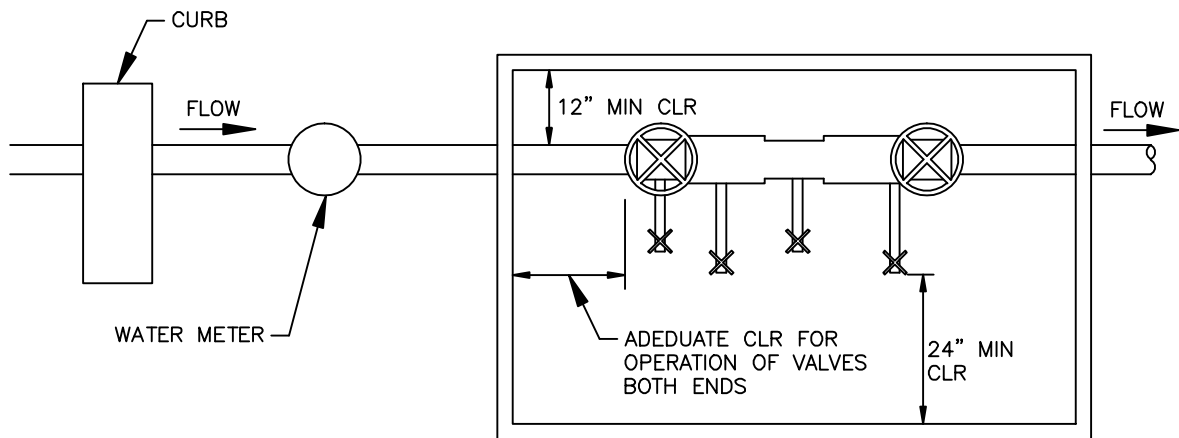

PLAN VIEW

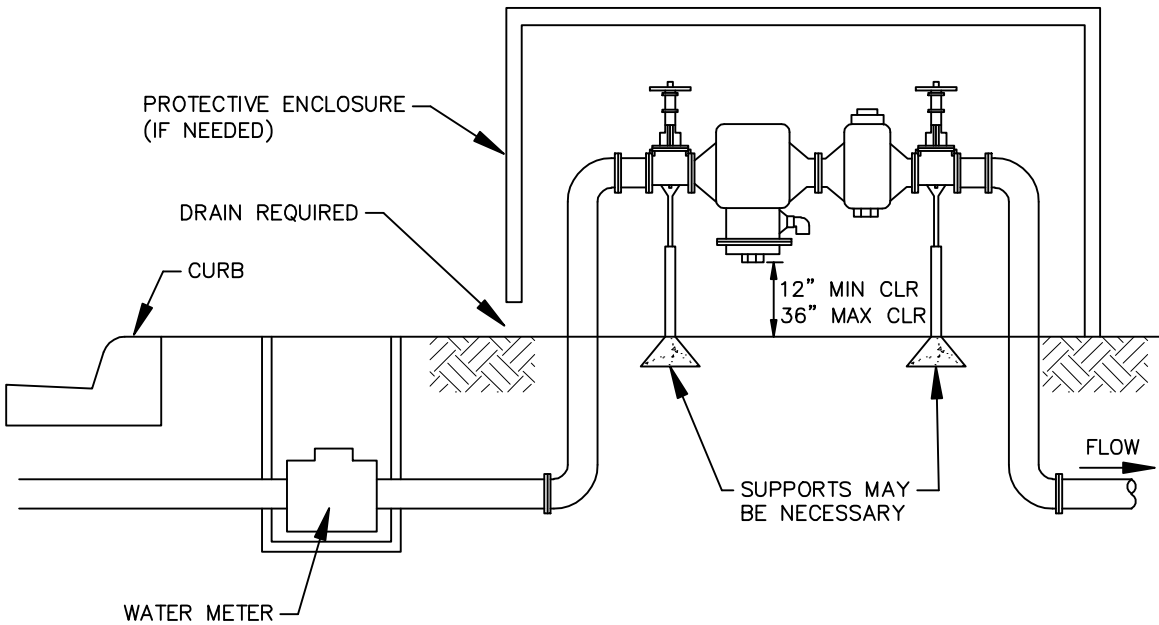

ABOVE GROUND

**SPRINGS HILL SPECIAL UTILITY DISTRICT**

**REDUCE PRESSURE PRINCIPLE  
BACKFLOW PREVENTER**

DATE:  
11/24/2009

REVISIONS:

STANDARD NO.  
WA-11

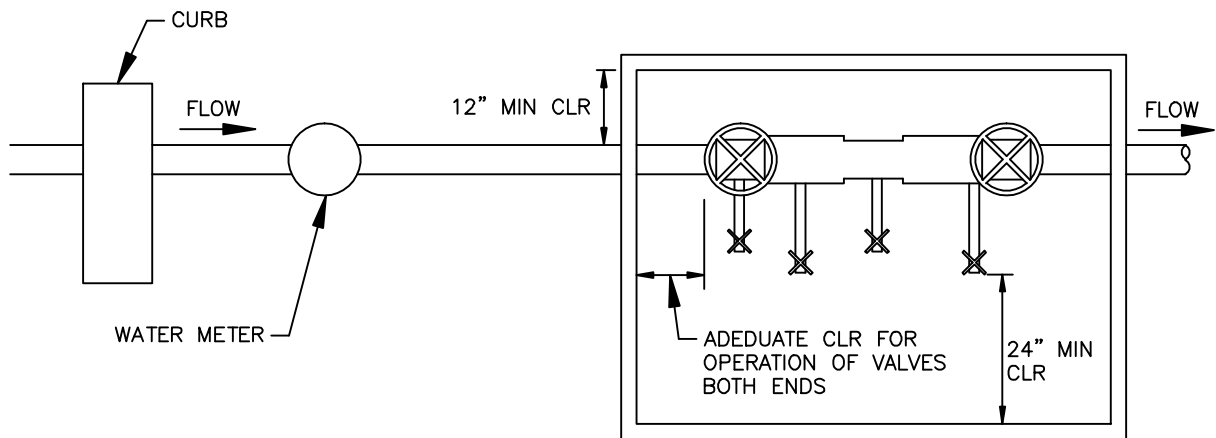

PLAN VIEW

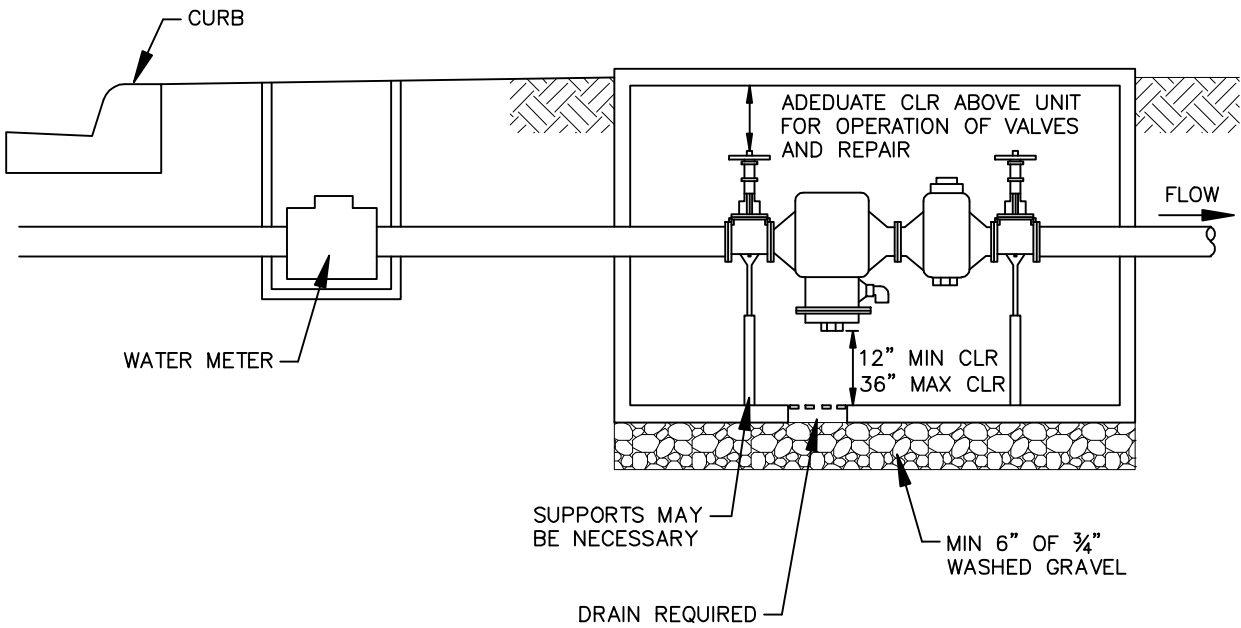

BELOW GROUND

**SPRINGS HILL SPECIAL UTILITY DISTRICT**

**REDUCE PRESSURE PRINCIPLE  
BACKFLOW PREVENTER**

DATE:  
11/24/2009

REVISIONS:

STANDARD NO.  
WA-12

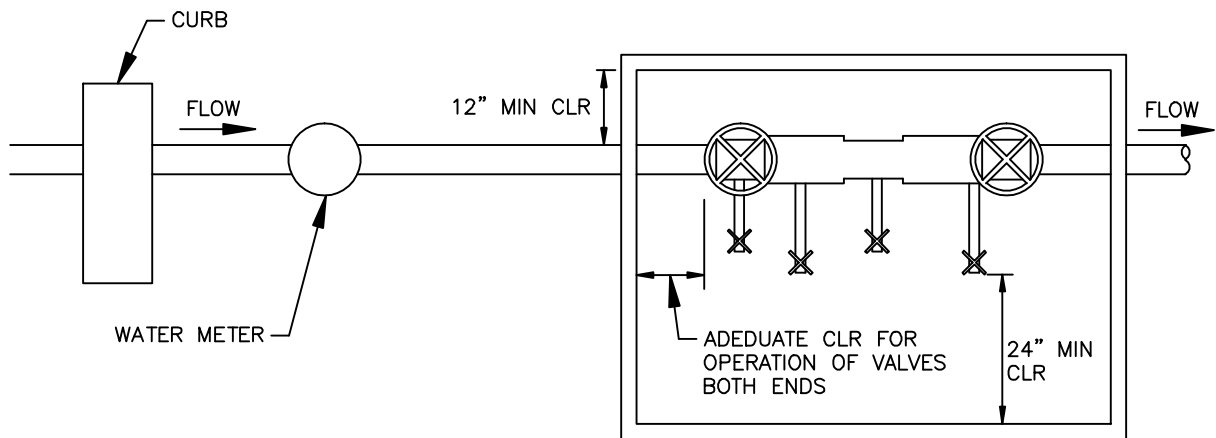

PLAN VIEW

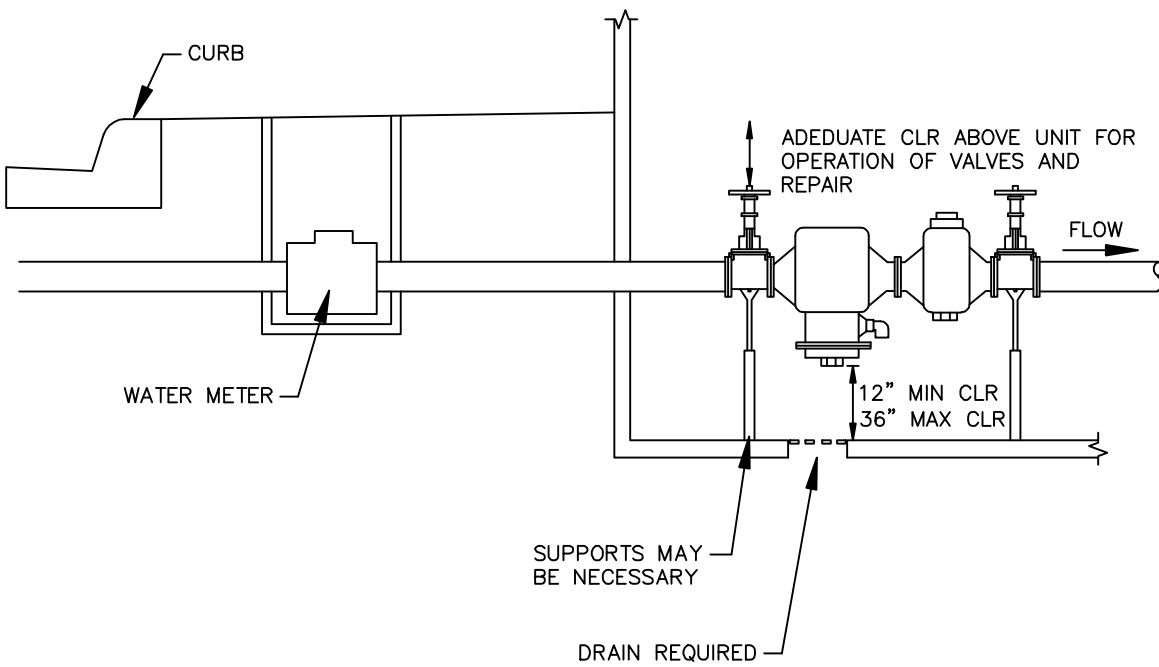

IN BUILDING

**SPRINGS HILL SPECIAL UTILITY DISTRICT**

**REDUCE PRESSURE PRINCIPLE  
BACKFLOW PREVENTER**

DATE:  
11/24/2009

REVISIONS:

STANDARD NO.  
WA-13

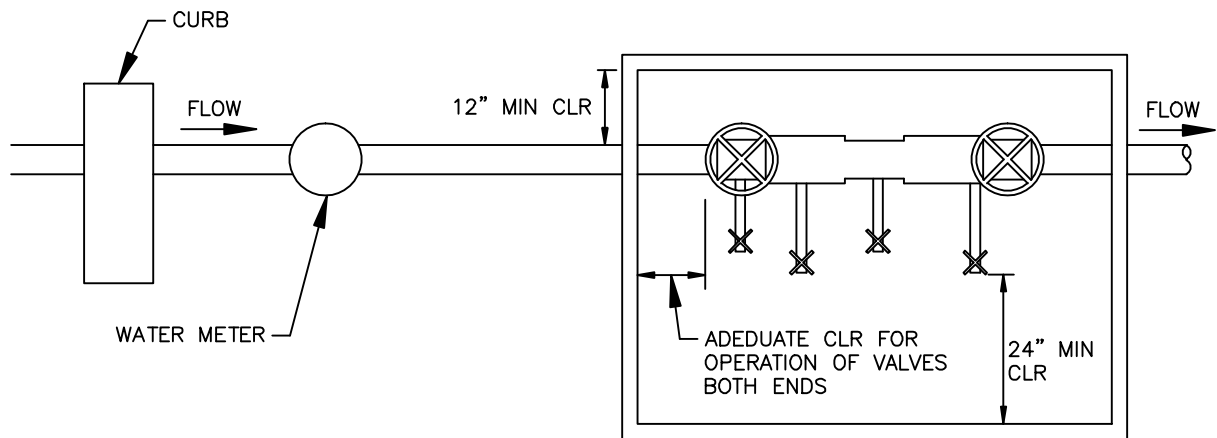

PLAN VIEW

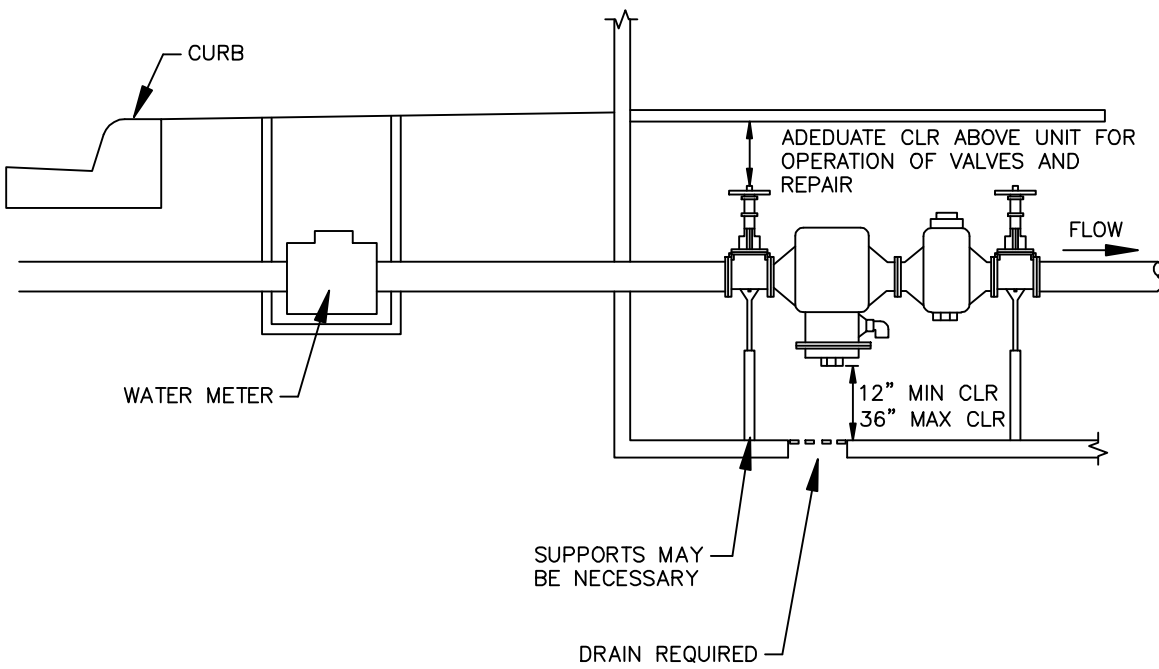

IN BASEMENT

**SPRINGS HILL SPECIAL UTILITY DISTRICT**

**REDUCE PRESSURE PRINCIPLE  
BACKFLOW PREVENTER**

DATE:  
11/24/2009

REVISIONS:

STANDARD NO.  
WA-14

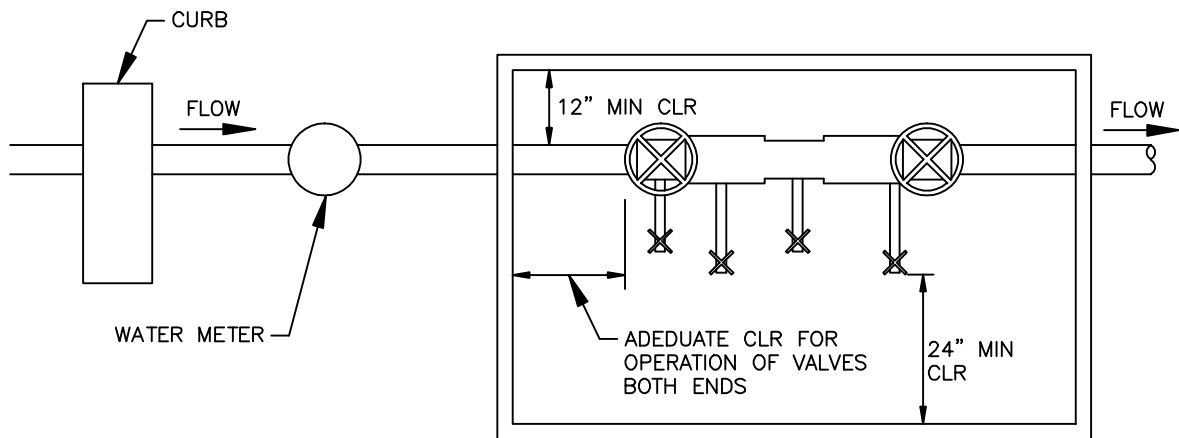

PLAN VIEW

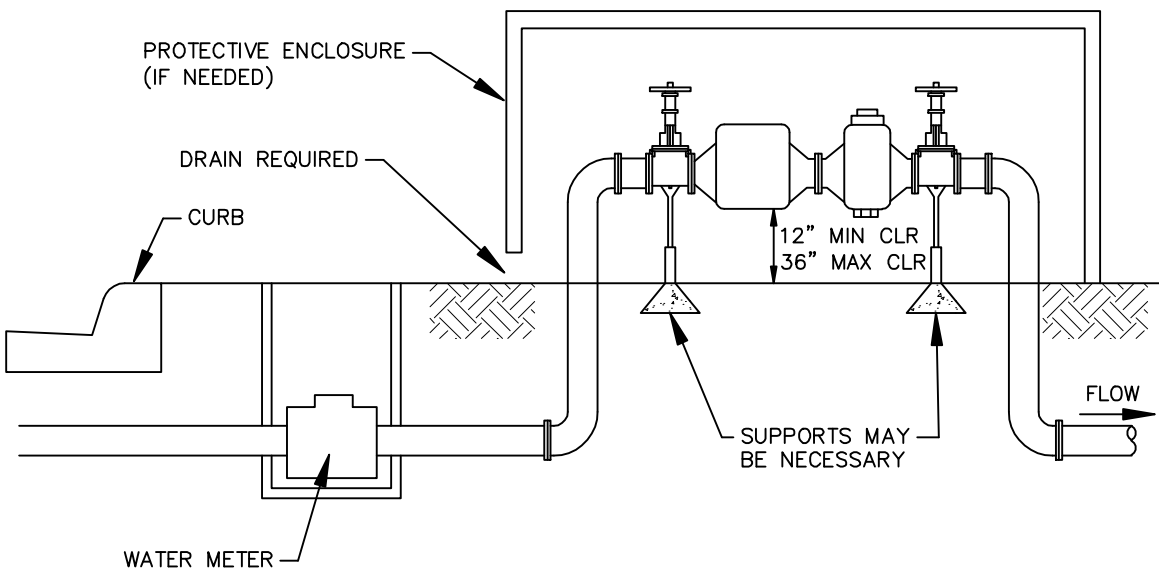

ABOVE GROUND

**SPRINGS HILL SPECIAL UTILITY DISTRICT**

**DOUBLE CHECK VALVE  
BACKFLOW PREVENTER**

DATE:  
11/24/2009

REVISIONS:

STANDARD NO.  
WA-15

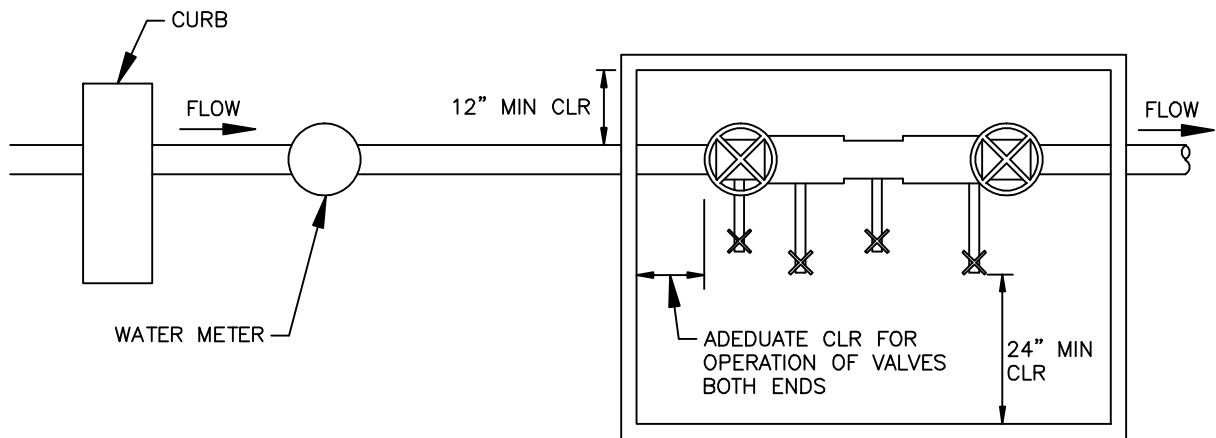

PLAN VIEW

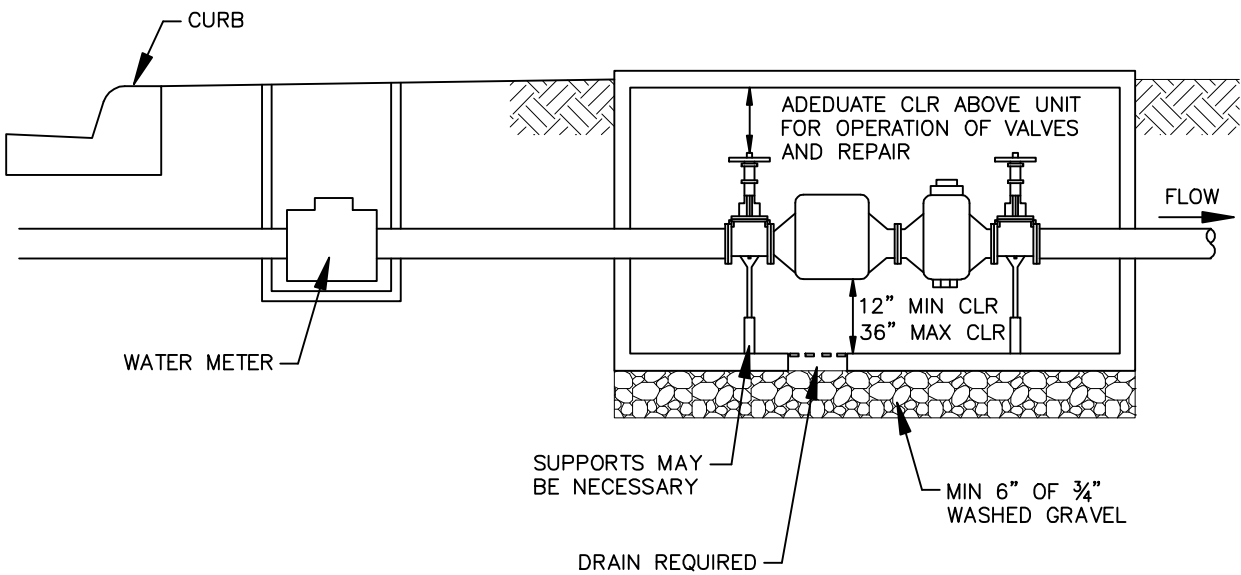

BELOW GROUND

**SPRINGS HILL SPECIAL UTILITY DISTRICT**

**DOUBLE CHECK VALVE  
BACKFLOW PREVENTER**

DATE:  
11/24/2009

REVISIONS:

STANDARD NO.  
WA-16

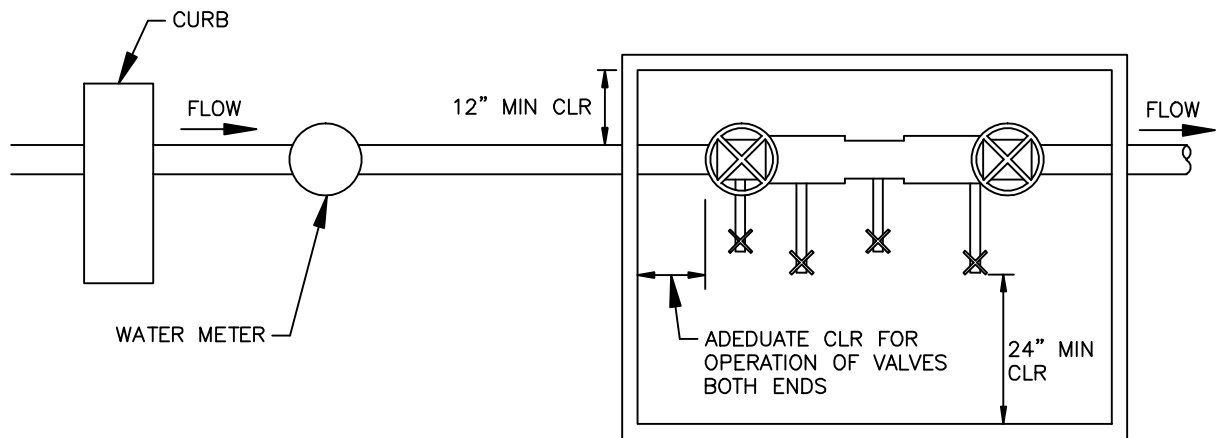

PLAN VIEW

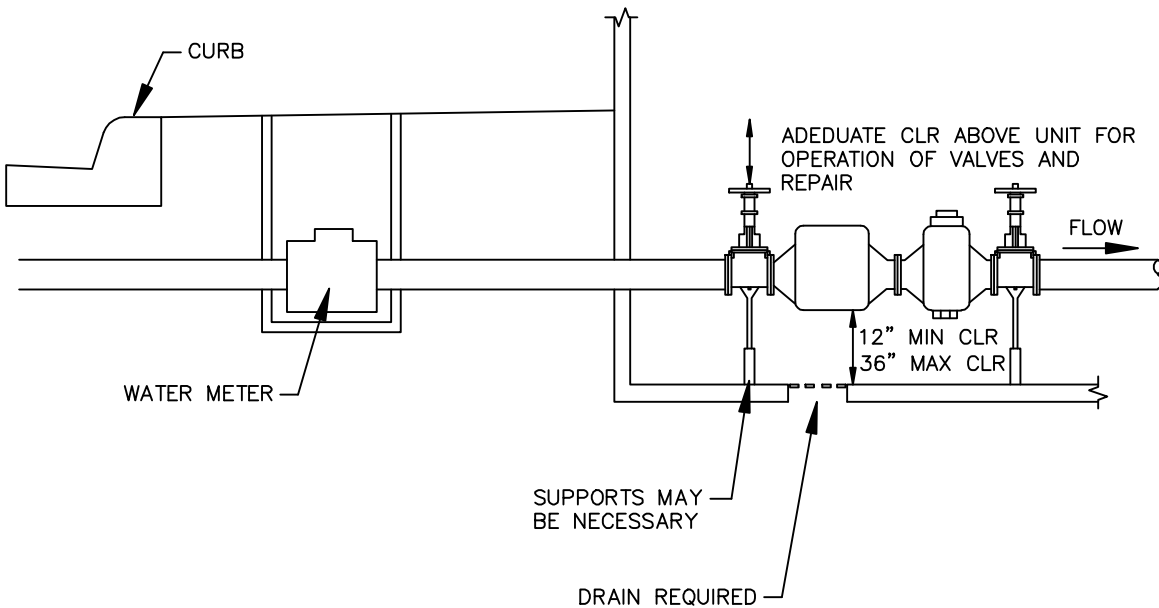

IN BUILDING

**SPRINGS HILL SPECIAL UTILITY DISTRICT**

**DOUBLE CHECK VALVE  
BACKFLOW PREVENTER**

DATE:  
11/24/2009

REVISIONS:

STANDARD NO.  
WA-17



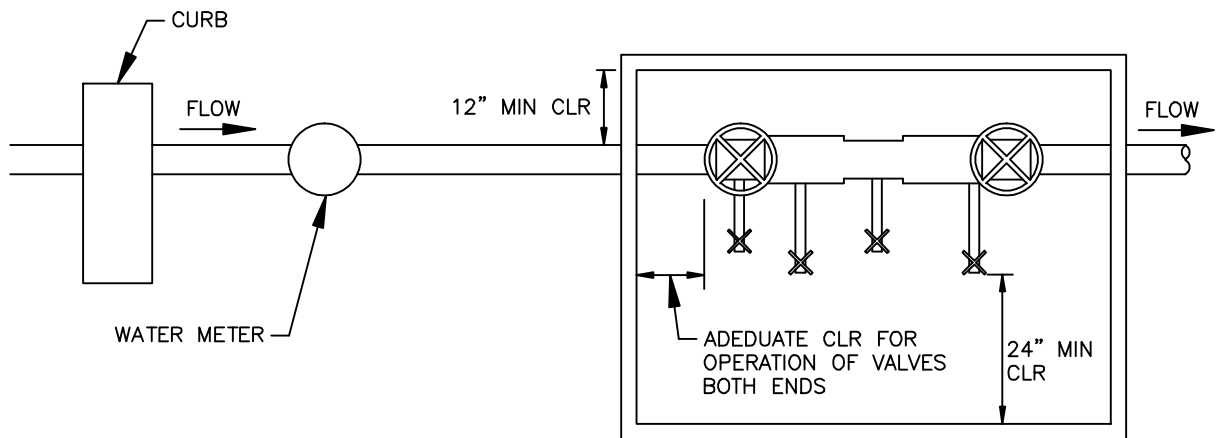

PLAN VIEW

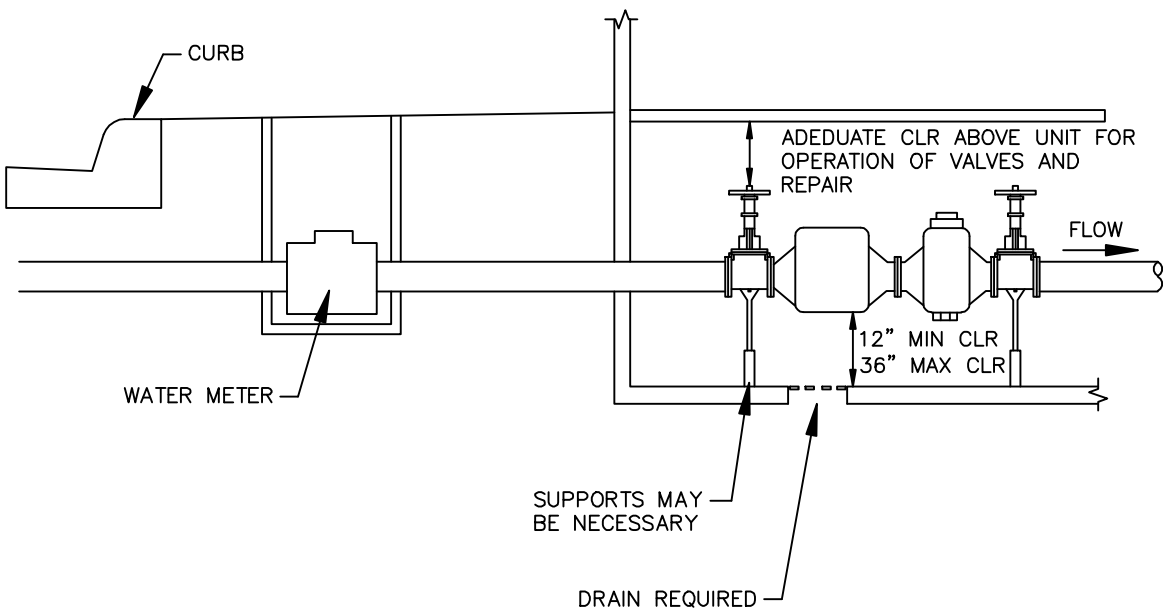

IN BASEMENT

**SPRINGS HILL SPECIAL UTILITY DISTRICT**

**DOUBLE CHECK VALVE  
BACKFLOW PREVENTER**

DATE:  
11/24/2009

REVISIONS:

STANDARD NO.  
WA-18

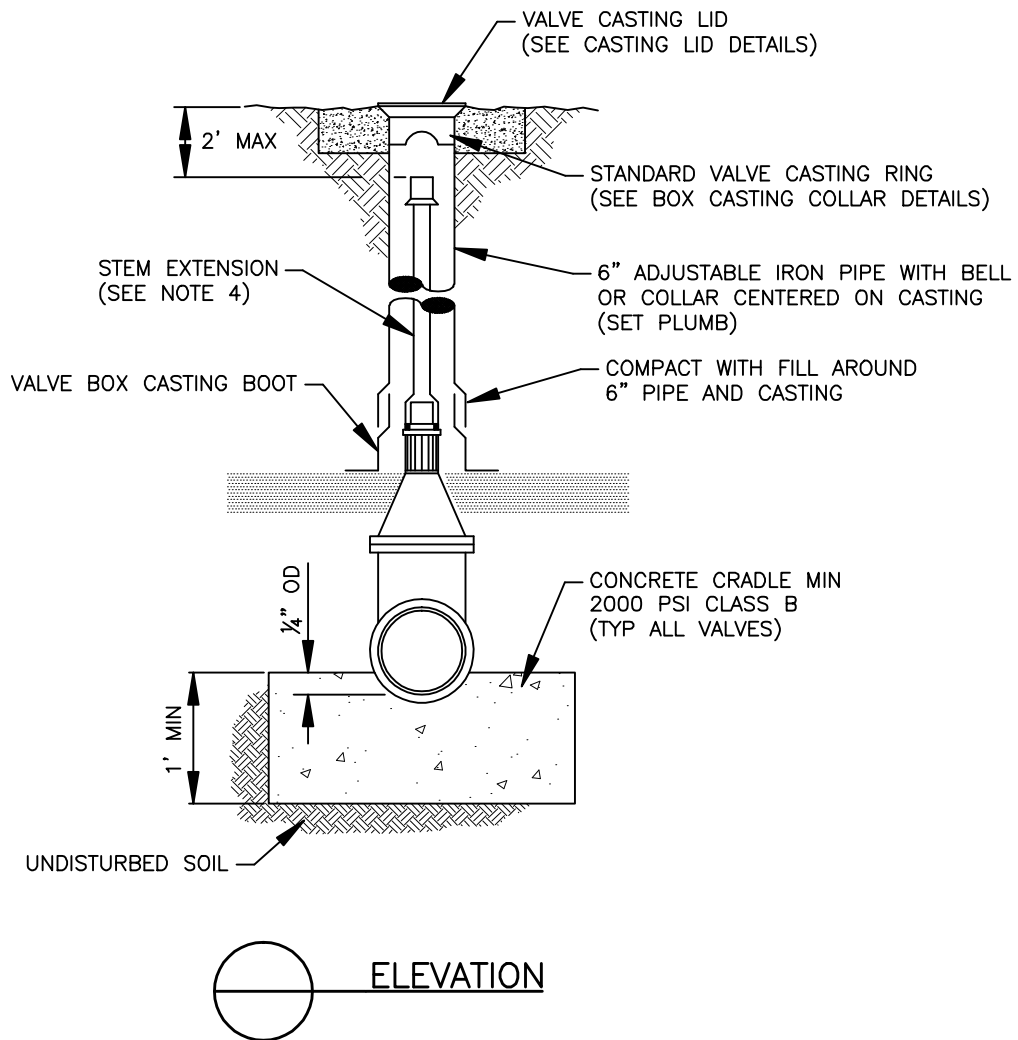

NOTES:

1. WELD SOCKET 2½" X 2" DEEP TO 1" (SCH. 40) ROUND STEM EXTENSION. FITTED ON OPERATING NUT, SCH. 80 FOR LENGTHS OVER 10'.
2. STANDARD VALVE CASTING RING AND METAL LID IN UNPAVED AREAS.
3. NUT AT TOP OF VALVE EXTENSION ROD SHALL BE SQUARE 2" LONG WELDED TO TOP OF ROD.
4. VALVE EXTENSIONS ARE REQUIRED ON ALL VALVES THAT EXCEED 3 FEET DEEP FROM FINISHED GRADE. VALVE EXTENSIONS SHALL BE PLACED SUCH THAT THE EXTENSION NUT IS BETWEEN 18 TO 24 INCHES FROM FINISHED GRADE.

**SPRINGS HILL SPECIAL UTILITY DISTRICT**

**4" TO 24" VERTICAL GATE VALVE  
WITH BOX ASSEMBLY**

DATE:  
06/15/2010

REVISIONS:

STANDARD NO.  
WA-19

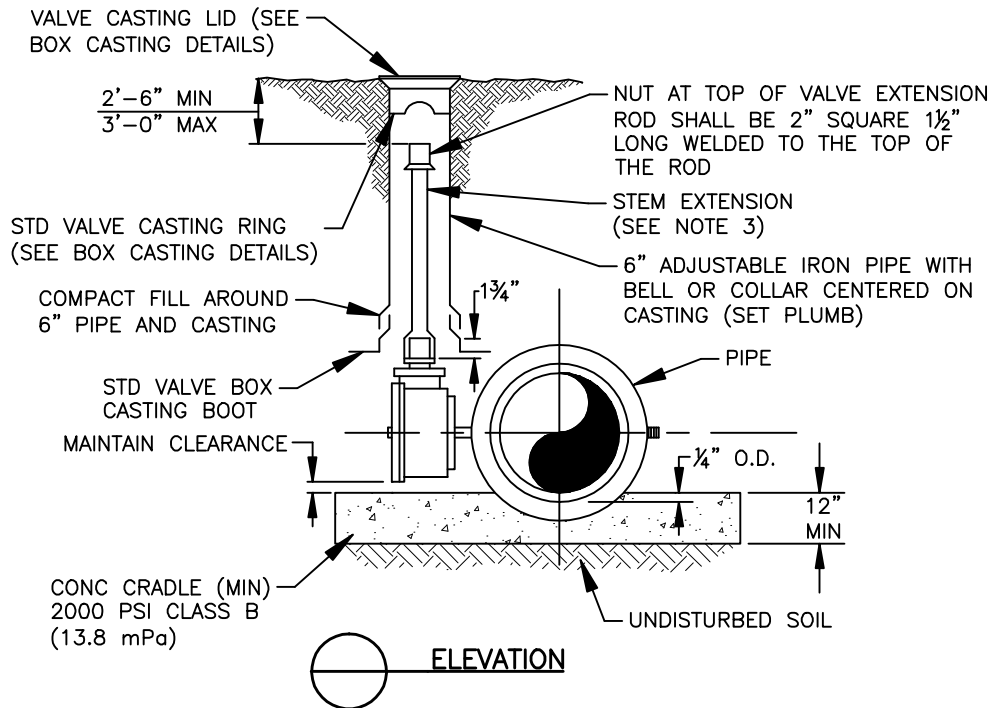
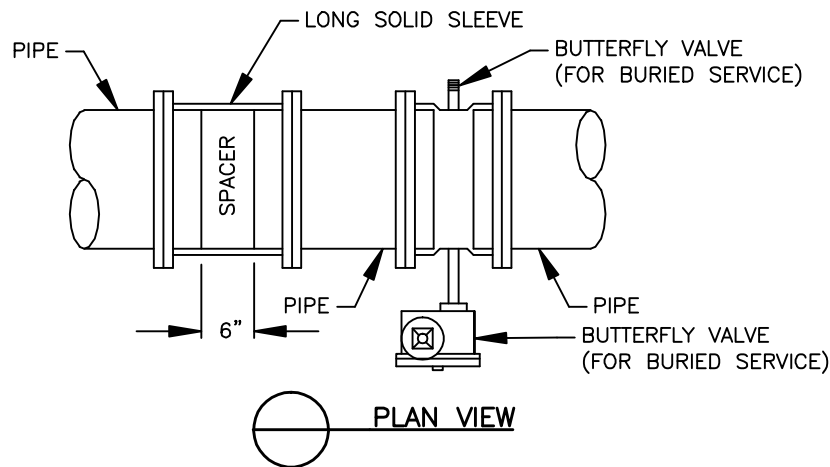

NOTES:

1. WELD SOCKET  $2\frac{5}{8}$ "x $1\frac{1}{4}$ " DEEP TO  $1\frac{1}{8}$ " SOLID ROUND STEM EXTENSION.
2. SPRINGS HILL SPECIAL UTILITY DISTRICT (SHSUD) STANDARD VALVE CASING RING AND LID. (TRAFFIC BEARING IN PAVED AREAS).
3. VALVE EXTENSIONS ARE REQUIRED ON ALL VALVES THAT EXCEED 3 FEET DEEP FROM FINISHED GRADE. VALVE EXTENSIONS SHALL BE PLACED SUCH THAT THE EXTENSION WITH BOX ASSEMBLY IS NOT BETWEEN 18 TO 24 INCHES FROM FINISHED GRADE.

**SPRINGS HILL SPECIAL UTILITY DISTRICT**

**36" AND UP BUTTERFLY VALVE  
WITH BOX ASSEMBLY**

DATE:  
06/15/2010

REVISIONS:

STANDARD NO.  
WA-20

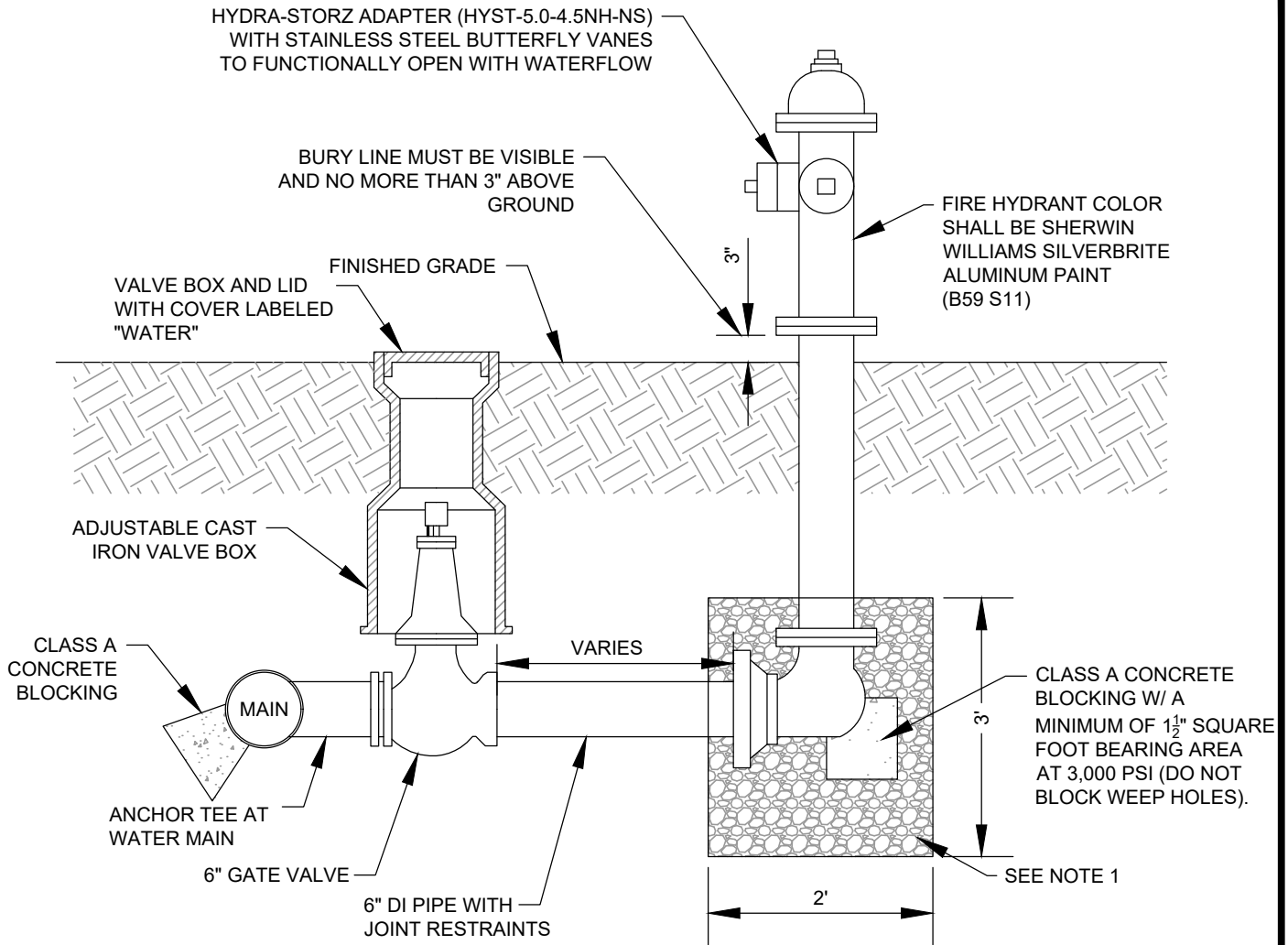

NOTES:

1. A MINIMUM OF 2 CUBIC FEET OF 1" TO 2" CLEAN, ASTM C-33 CRUSHED STONE #67 SHALL BE PLACED AROUND THE BOTTOM OF THE HYDRANT FOR A RADIUS OF AT LEAST 10" AND EXTEND 10" ABOVE THE OUTLET. DO NOT BLOCK DRAIN HOLES.
2. ALL PIPE JOINTS SHALL BE KEPT FREE FROM CONCRETE.
3. ALL FITTINGS AND FITTING JOINTS MUST BE WRAPPED WITH THREE LAYERS OF 8-MIL POLYETHYLENE IN ACCORDANCE WITH AWWA C105-10, OR LATEST VERSIONS THERE OF.
4. POLYWRAP SHALL BE SECURED WITH A MINIMUM OF THREE CIRCUMFERENTIAL TURNS OF POLYTAPE.
5. THE FIRE HYDRANT SHALL BE PLACED A MINIMUM OF 5 FEET FROM ALL OBSTRUCTIONS.
6. ALL NEW FIRE HYDRANTS SHALL BE MARKED WITH A FOUR-INCH BY FOUR-INCH BY THREE-FOURTHS-INCH TALL, BLUE REFLECTIVE PAVEMENT MARKER (BLUE REFLECTIVE EYE) LOCATED THREE FEET OFF-CENTER OF THE STREET TOWARDS THE HYDRANT. ALL MARKERS MUST BE APPROVED BY FIRE AND UTILITIES DEPARTMENT.
7. FIRE FLOW SHALL BE TESTED WITH THE FLOWS AND PRESSURES PROVIDED TO SHSUD
8. ALL VALVES AND FIRE HYDRANTS SHALL BE LOCATED BY GPS AND PROVIDED TO SHSUD : IN TEXAS STATE PLANE COORDINATES, NAD 83 (93) SOUTH CENTRAL ZONE.
9. INSTALL ONE INLINE GATE VALVE AT EACH SIDE OF TEE THAT CONNECTS FIRE HYDRANT ASSEMBLY TO WATER MAIN.

**SPRINGS HILL SPECIAL UTILITY DISTRICT**

**STANDARD FIRE HYDRANT INSTALLATION**

DATE:

8/20/2021

REVISIONS:

STANDARD NO.

WA-21

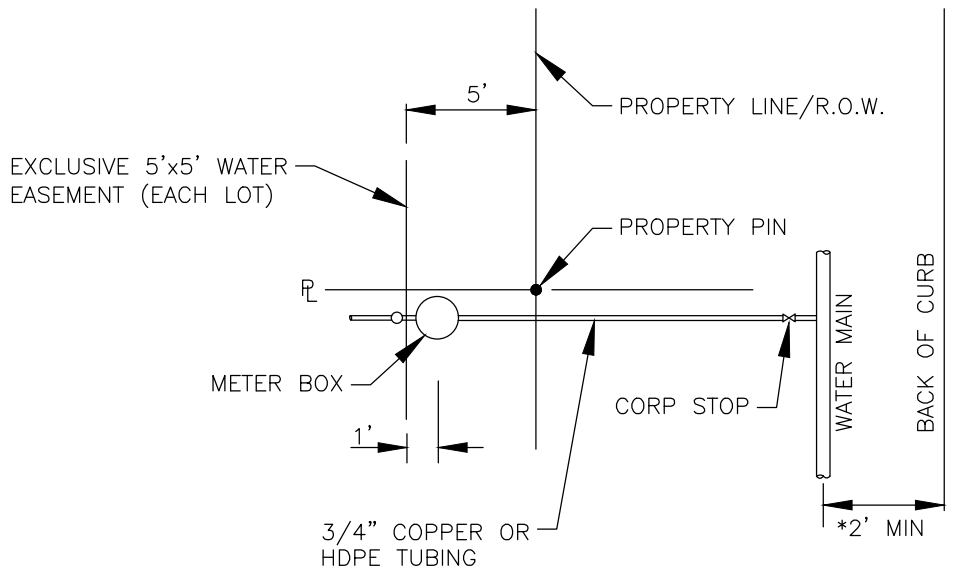

\*THIS DIMENSION MAY BE INCREASED BY WIDTH OF SIDEWALK, IF SIDEWALK IS LOCATED AT CURB.

NOTES:

1. INSTALLATIONS SHALL BE MADE IN ACCORDANCE WITH INFORMATION SHOWN ON APPLICABLE STANDARD DRAWINGS AND WILL BE INSPECTED BY SHSUD CONSTRUCTION INSPECTION PERSONNEL.
2. CUSTOMER ALSO INSTALLS WATER LINES INCLUDING FITTINGS AND VALVES ON BOTH SIDES OF METER, INSTALL METER BOXES AND COVERS. ALL IN ACCORDANCE WITH INFORMATION ON APPLICABLE STANDARD DRAWING. A VENTED SPACER MAY BE USED TO ASSURE PROPER SPACING AND ALIGNMENT OF METER FITTINGS.
3. CUSTOMER IS RESPONSIBLE FOR METER BOX AND PIPING SYSTEM UNTIL METER IS INSTALLED AND WATER IS CONNECTED. ANY MISSING OR DAMAGED PARTS SHALL BE REINSTALLED BY CUSTOMER WHO SHALL GUARANTEE, FOR A PERIOD OF ONE (1) YEAR FROM DATE OF ACCEPTANCE, THAT CONNECTIONS TO SHSUD SYSTEMS ARE FREE FROM DEFECTS IN WORKMANSHIP OR MATERIAL. CUSTOMER ALSO HAS THE RESPONSIBILITY TO ASSURE THAT ALL VALVES AND STOPS, METER BOX AND REMAIN CLEAR OF SIDEWALKS AND OTHER OBSTRUCTIONS.
4. SHSUD ACTIVITY IS LIMITED TO INSTALLATION OF THE WATER METER AND INSPECTION OF CONNECTIONS TO SHSUD WATER SYSTEMS. FOR MAINTENANCE PURPOSES, SHSUD RESPONSIBILITY ENDS AT THE CUSTOMER'S WATER CUT-OFF VALVE.
5. NO METER BOX SHALL BE SET IN SIDEWALK OR DRIVEWAY AREA WITHOUT WRITTEN APPROVAL FROM SHSUD.
6. PIPING AND TUBING IN STREET RIGHT-OF-WAY AND IN EASEMENT AREA SHALL BE BEDDED IN GRANULAR MATERIAL AS REQUIRED IN THE SPECIFICATIONS. SERVICE LINES SHALL HAVE A MINIMUM COVER BELOW FINAL GRADE OF 42-INCHES.

**SPRINGS HILL SPECIAL UTILITY DISTRICT**

**SINGLE WATER SERVICE CONNECTION**

DATE:  
06/16/2010

REVISIONS:  
03/15/2022

STANDARD NO.  
WA-22

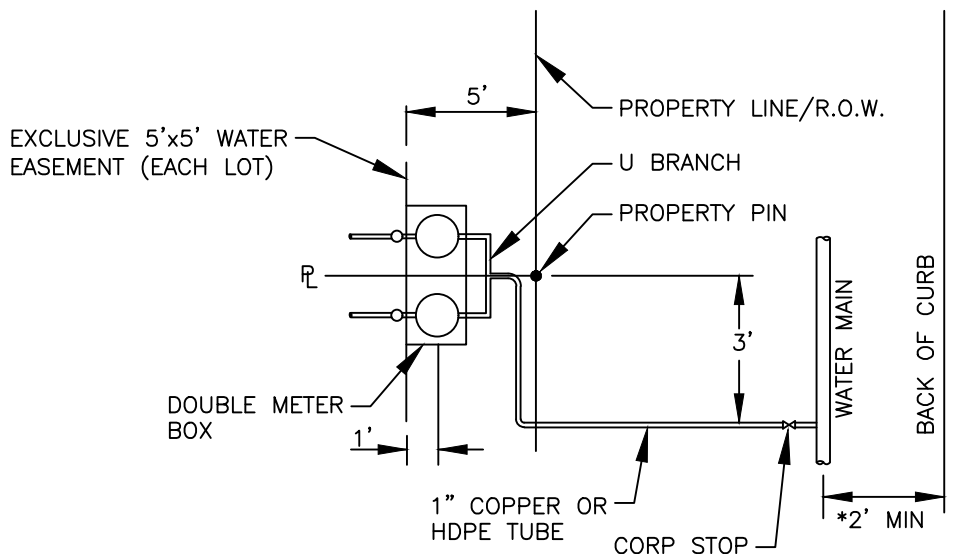

\*THIS DIMENSION MAY BE INCREASED BY WIDTH OF SIDEWALK, IF SIDEWALK IS LOCATED AT CURB.

NOTES:

1. INSTALLATIONS SHALL BE MADE IN ACCORDANCE WITH INFORMATION SHOWN ON APPLICABLE STANDARD DRAWINGS AND WILL BE INSPECTED BY SHSUD CONSTRUCTION INSPECTION PERSONNEL.
2. CUSTOMER ALSO INSTALLS WATER LINES INCLUDING FITTINGS AND VALVES ON BOTH SIDES OF METER, INSTALL METER BOXES AND COVERS. ALL IN ACCORDANCE WITH INFORMATION ON APPLICABLE STANDARD DRAWING. A VENTED SPACER MAY BE USED TO ASSURE PROPER SPACING AND ALIGNMENT OF METER FITTINGS.
3. CUSTOMER IS RESPONSIBLE FOR METER BOX AND PIPING SYSTEM UNTIL METER IS INSTALLED AND WATER IS CONNECTED. ANY MISSING OR DAMAGED PARTS SHALL BE REINSTALLED BY CUSTOMER WHO SHALL GUARANTEE, FOR A PERIOD OF ONE (1) YEAR FROM DATE OF ACCEPTANCE, THAT CONNECTIONS TO SHSUD SYSTEMS ARE FREE FROM DEFECTS IN WORKMANSHIP OR MATERIAL. CUSTOMER ALSO HAS THE RESPONSIBILITY TO ASSURE THAT ALL VALVES AND STOPS, METER BOX AND REMAIN CLEAR OF SIDEWALKS AND OTHER OBSTRUCTIONS.
4. SHSUD ACTIVITY IS LIMITED TO INSTALLATION OF THE WATER METER AND INSPECTION OF CONNECTIONS TO SHSUD WATER SYSTEMS. FOR MAINTENANCE PURPOSES, SHWSC RESPONSIBILITY ENDS AT THE CUSTOMER'S WATER CUT-OFF VALVE.
5. NO METER BOX SHALL BE SET IN SIDEWALK OR DRIVEWAY AREA WITHOUT WRITTEN APPROVAL FROM SHSUD
6. PIPING AND TUBING IN STREET RIGHT-OF-WAY AND IN EASEMENT AREA SHALL BE BEDDED IN GRANULAR MATERIAL AS REQUIRED IN THE SPECIFICATIONS. SERVICE LINES SHALL HAVE A MINIMUM COVER BELOW FINAL GRADE OF 42 INCHES.

**SPRINGS HILL SPECIAL UTILITY DISTRICT**

**DOUBLE WATER SERVICE CONNECTION**

DATE: 07/23/2010	REVISIONS: 03/15/2022	STANDARD NO. WA-23
---------------------	--------------------------	-----------------------

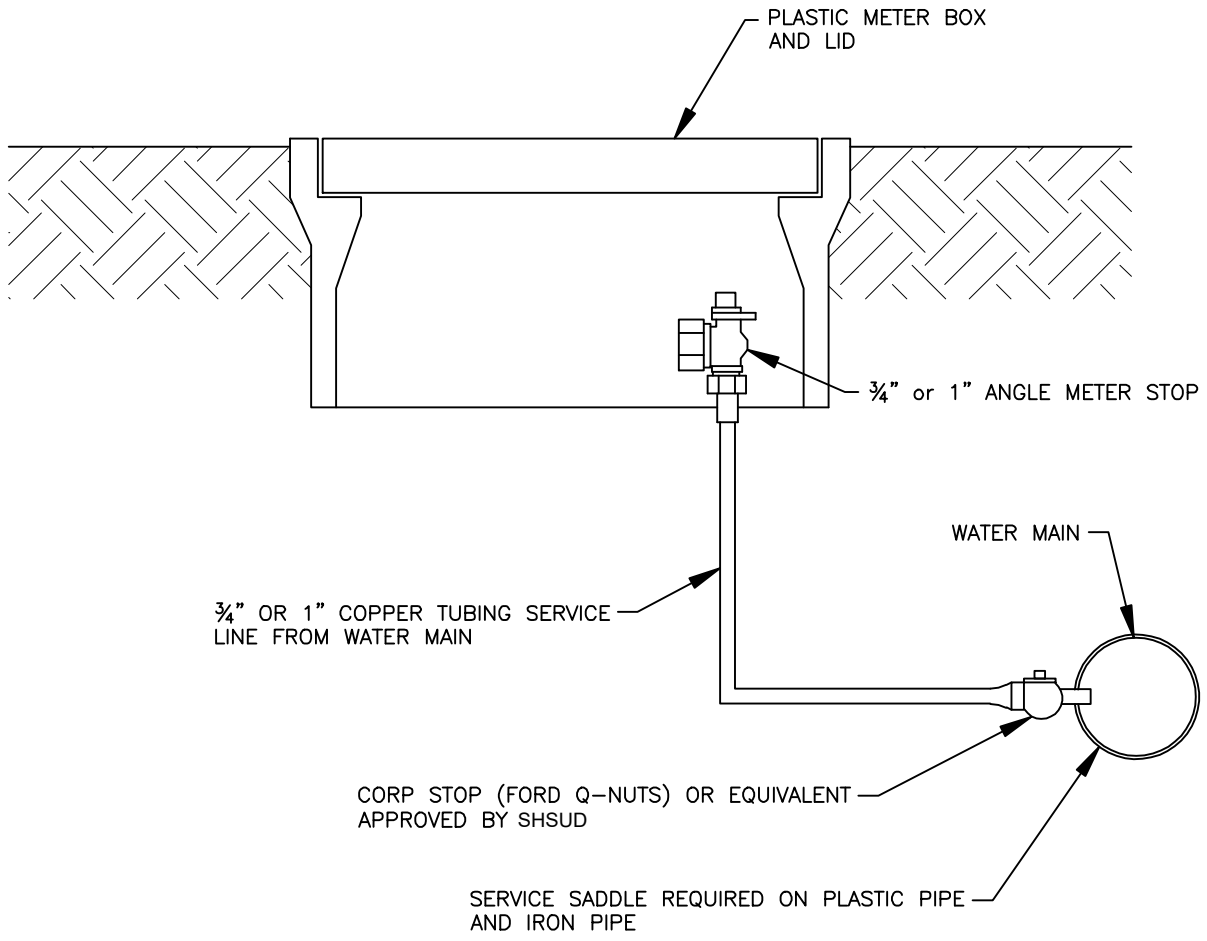

**SPRINGS HILL SPECIAL UTILITY DISTRICT**

**3/4" AND 1" SERVICE INSTALLATION**

DATE:  
11/24/2009

REVISIONS:

STANDARD NO.  
WA-24

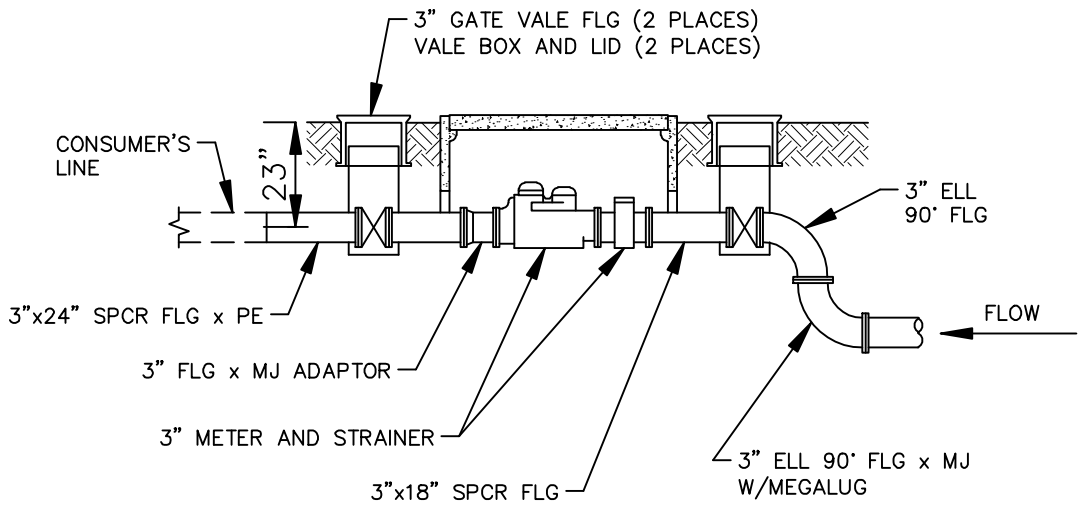

**SPRINGS HILL SPECIAL UTILITY DISTRICT**

**STANDARD 3" SERVICE CONNECTION INSTALLATION**

DATE:  
11/24/2009

REVISIONS:

STANDARD NO.  
WA-25



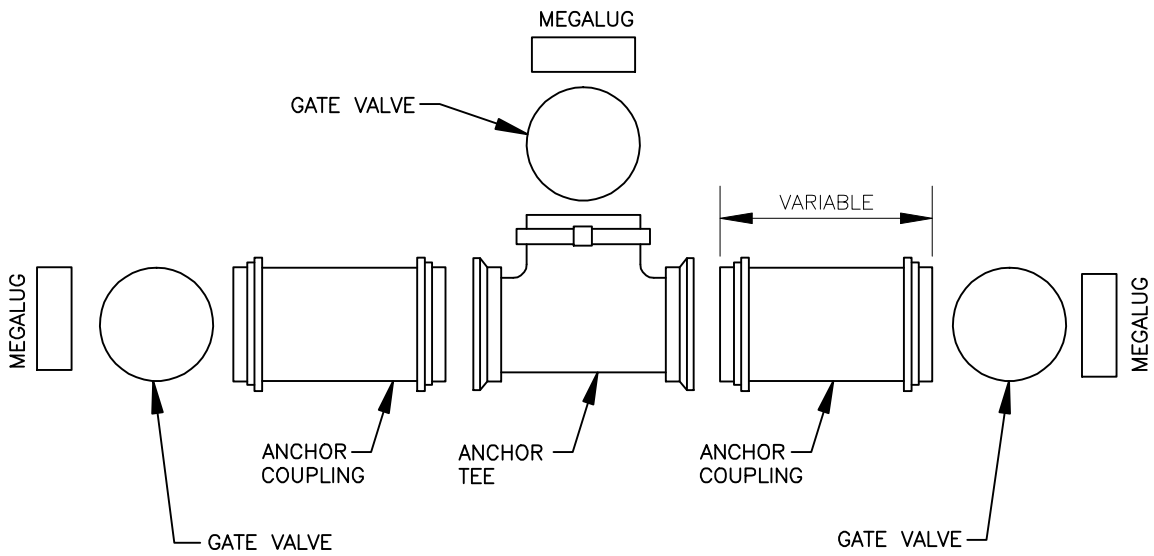

**SPRINGS HILL SPECIAL UTILITY DISTRICT**

**STANDARD VALVE BANK INSTALLATION**

DATE:  
11/24/2009

REVISIONS:

STANDARD NO.  
WA-26

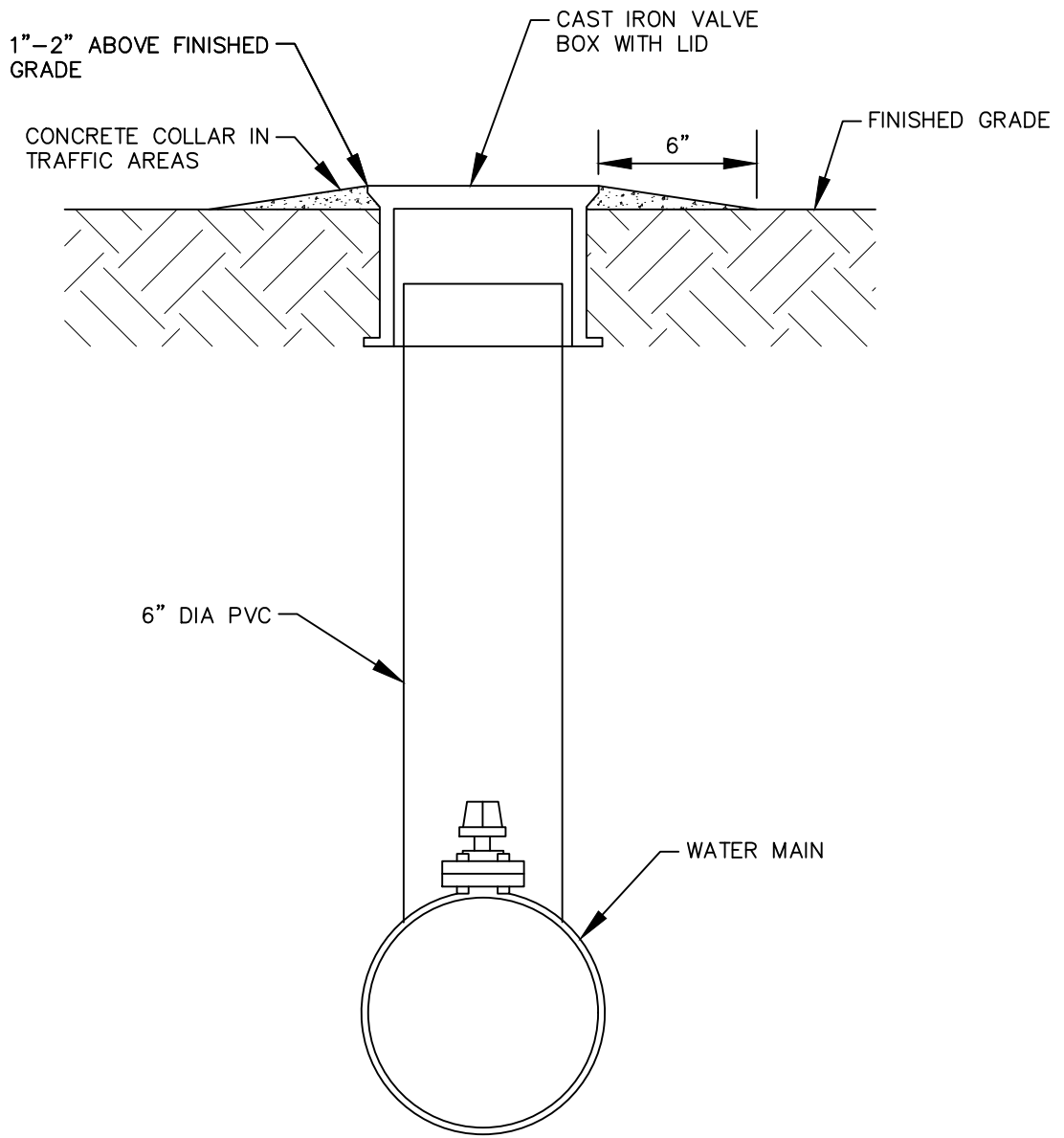

**SPRINGS HILL SPECIAL UTILITY DISTRICT**

**STANDARD VALVE BOX INSTALLATION**

DATE:  
11/24/2009

REVISIONS:

STANDARD NO.  
WA-27

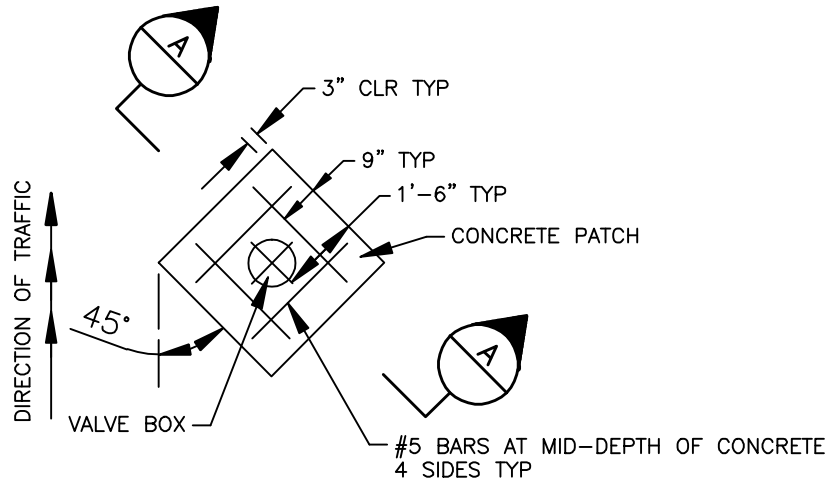

**PLAN VIEW**

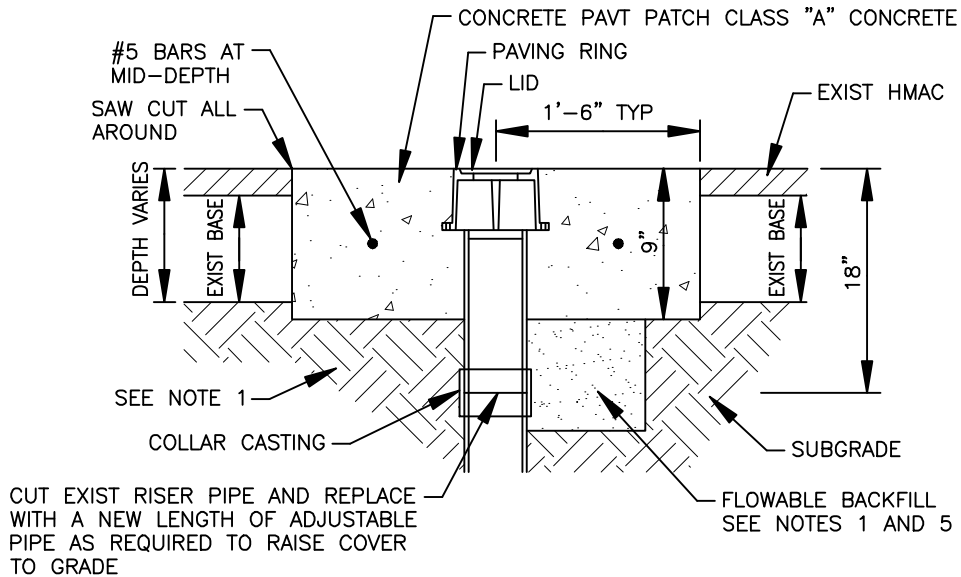

**SECTION A-A**

**NOTES:**

1. SUBGRADE SHALL BE COMPACTED AS PER SPECIFICATIONS, SUBGRADE PREPARATION.
2. VALVE CASTINGS SHALL BE ADJUSTED TO GRADE AFTER FINAL LIFT OF OVERLAY IS IN PLACE.
3. CLEAN VALVE BOX OF ALL DEBRIS DOWN TO THE BASE OF THE VALVE.
4. REMOVE EXISTING RISER PIPE DOWN 18" AND REPLACE TO THE NEW ELEVATION USING NEW ADJUSTABLE PIPE AND A CASTING.
5. WHERE CAST IRON CASTINGS TO BE REMOVED REQUIRE EXCAVATION GREATER THAN 20" DEEP. CONTRACTOR MAY ELECT TO FILL EXCAVATION WITH CONTROLLED LOW STRENGTH MATERIAL TO THE UNDERSIDE OF THE CONCRETE PAVEMENT PATCH IN LIEU OF COMPACTED BACKFILL.
6. REINFORCING STEEL SHALL MEET SPECIFICATIONS FOR REINFORCING STEEL.

**SPRINGS HILL SPECIAL UTILITY DISTRICT**

**VALVE BOX TO GRADE  
WITH FULL DEPTH CONCRETE**

DATE:  
08/12/2010

REVISIONS:

STANDARD NO.  
WA-28

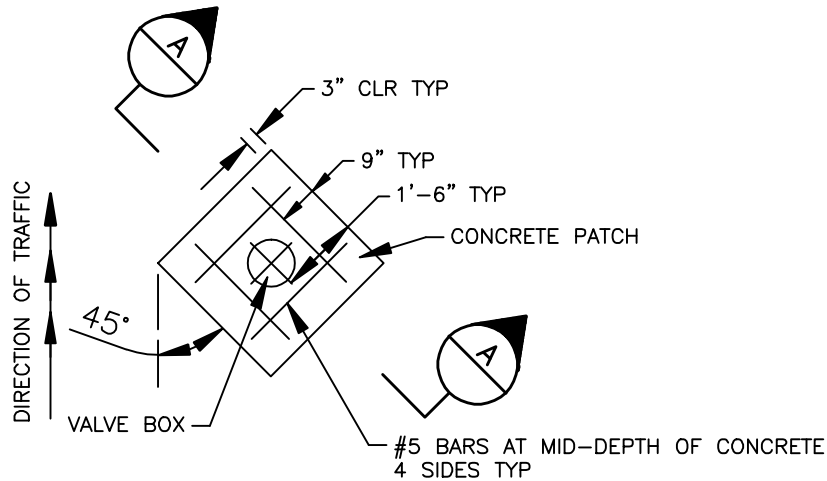

**PLAN VIEW**

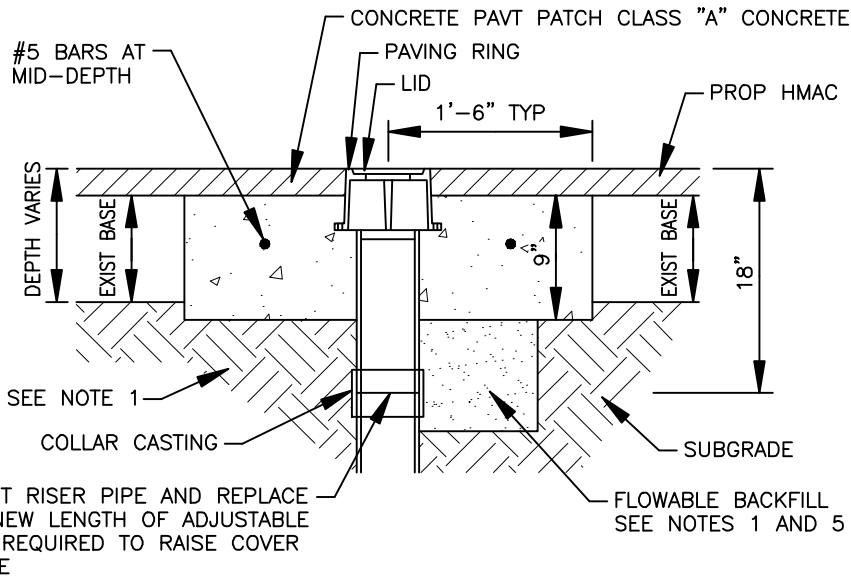

**SECTION A-A**

**NOTES:**

1. SUBGRADE SHALL BE COMPACTED AS PER SPECIFICATIONS, SUBGRADE PREPARATION.
2. VALVE CASTINGS SHALL BE ADJUSTED TO GRADE AFTER FINAL LIFT OF OVERLAY IS IN PLACE.
3. CLEAN VALVE BOX OF ALL DEBRIS DOWN TO THE BASE OF THE VALVE.
4. REMOVE EXISTING RISER PIPE DOWN 18" AND REPLACE TO THE NEW ELEVATION USING NEW ADJUSTABLE PIPE AND A CASTING.
5. WHERE CAST IRON CASTINGS TO BE REMOVED REQUIRE EXCAVATION GREATER THAN 20" DEEP. CONTRACTOR MAY ELECT TO FILL EXCAVATION WITH CONTROLLED LOW STRENGTH MATERIAL TO THE UNDERSIDE OF THE CONCRETE PAVEMENT PATCH IN LIEU OF COMPACTED BACKFILL.
6. REINFORCING STEEL SHALL MEET SPECIFICATIONS FOR REINFORCING STEEL.

**SPRINGS HILL SPECIAL UTILITY DISTRICT**

**VALVE BOX TO GRADE WITH CONCRETE AND HOT MIX ASPHALT CONCRETE**

DATE:  
08/12/2010

REVISIONS:

STANDARD NO.  
WA-29

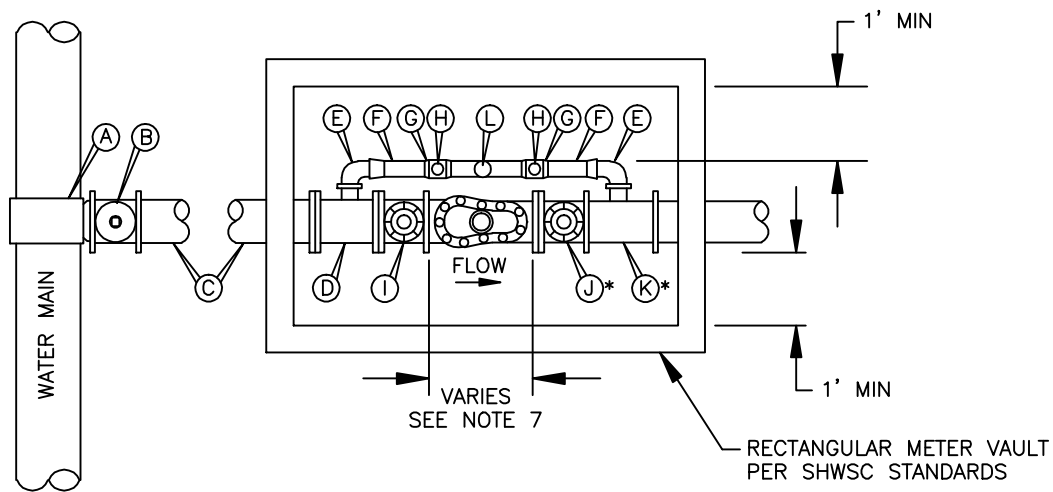
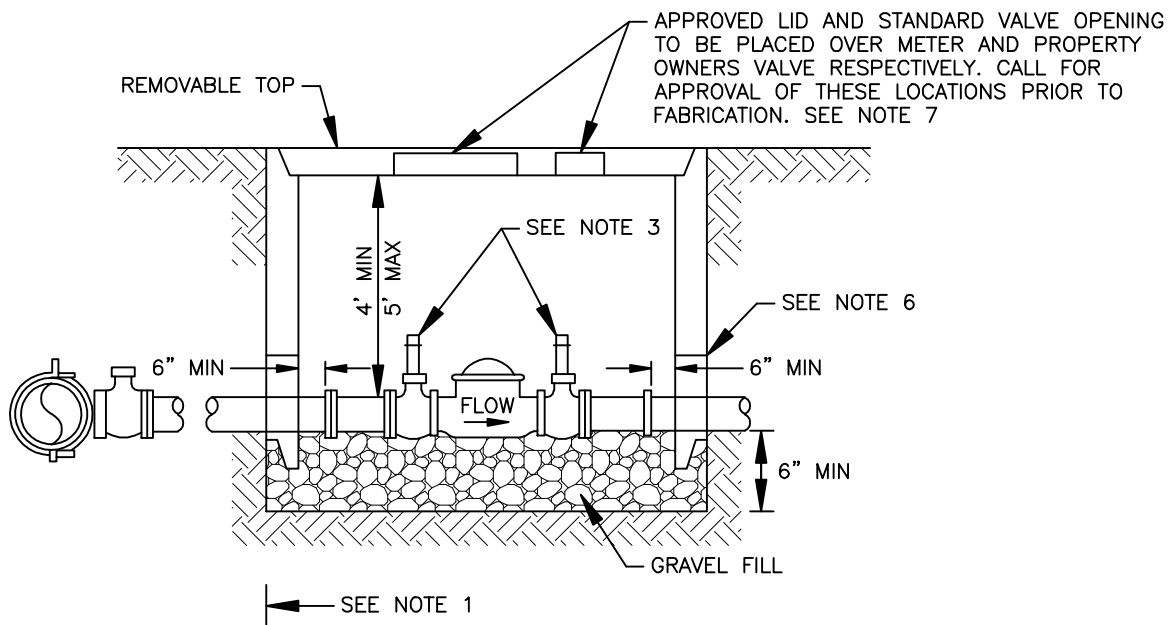

**SPRINGS HILL SPECIAL UTILITY DISTRICT**

**INSTALLATION DETAILS FOR 3", 4" AND 6"  
COMPOUND METERS SHEET 1 OF 2**

DATE:  
07/26/2010

REVISIONS:

STANDARD NO.  
WA-30

MATERIALS:

- A. APPROVED TAPPING SLEEVE
  - B. TAPPING VALVE (GATE) IRON BODY WITH M.J. OUTLET
  - C. DUCTILE IRON OR CAST IRON PIPE NOT LESS THAN 4" DIAMETER
  - D, TAPPED CAST IRON TEE – M.J. x SPIGOT
  - \*E. COPPER TO MALE IRON PIPE QUARTER BEND COUPLINGS.
  - F. 2" COPPER PIPE
  - G. COPPER TO MALE IRON PIPE FITTING
  - H. 2" BRASS BALL VALVE
  - I. SHUT OFF VALVE (GATE) CAST IRON MIN 4" FLANGED x M.J.
  - \*J. CUSTOMER'S VALVE (GATE) CAST IRON FLANGED
  - \*K. TAPPED CAST IRON TEE
  - L. METER ON 2" COPPER BY-PASS LINE
  - \* VALVE AND FITTING TO BE FURNISHED AND INSTALLED BY CUSTOMER.
- ITEMS D & K MAY BE LOCATED OUTSIDE THE BOX

NOTES:

- 1. BOX MUST BE BEHIND CURB AND/OR WALK AND OUT OF VEHICULAR TRAFFIC.
- 2. PIPE AND FITTINGS TO BE DUCTILE IRON OR CAST IRON EXCEPT AS NOTED. NO PLASTIC PIPE. NO SOLDERED JOINTS.
- 3. NO RISING STEM OR WHEEL OPERATED VALVES EXCEPT ON 2" BY-PASS VALVES.
- 4. ROD RESTRAINT IS REQUIRED AT ALL MECHANICAL OR PUSH ON TYPE JOINTS.
- 5. TOP OF BOX MUST BE 1" ABOVE GROUND OR FLUSH WITH PAVEMENT SURFACE.
- 6. METER BOX TO BE SET AFTER METER IS INSTALLED. SIDE NOTCHES IN BOX TO BE FILLED WITH MORTAR AFTER INSTALLATION OF PIPE.
- 7. CONTACT SHSUD FOR METER LENGTH, APPROVED TYPE OF LID AND LOCATION OF OPENINGS IN TOP OF BOX.
- 8. ANY WORK BY CUSTOMER ON THE CITY SIDE OF THE METER REQUIRES PLANS BY A TEXAS REGISTERED/LICENSED PROFESSIONAL ENGINEER.
- 9. WHERE THERE IS A LOOPED SYSTEM WITH MORE THAN ONE METER, APPROVED CHECK VALVES SHALL BE INSTALLED DOWNSTREAM OF THE PROPERTY OWNERS GATE VALVE (J) AT EACH METER. BACKFLOW PREVENTERS MAY BE REQUIRED WITHIN THE SYSTEM BY THE BUILDING INSPECTION DEPARTMENT.

**SPRINGS HILL SPECIAL UTILITY DISTRICT**

**INSTALLATION DETAILS FOR 3", 4" AND 6"  
COMPOUND METERS SHEET 2 OF 2**

DATE:  
07/26/2010

REVISIONS:

STANDARD NO.  
WA-30

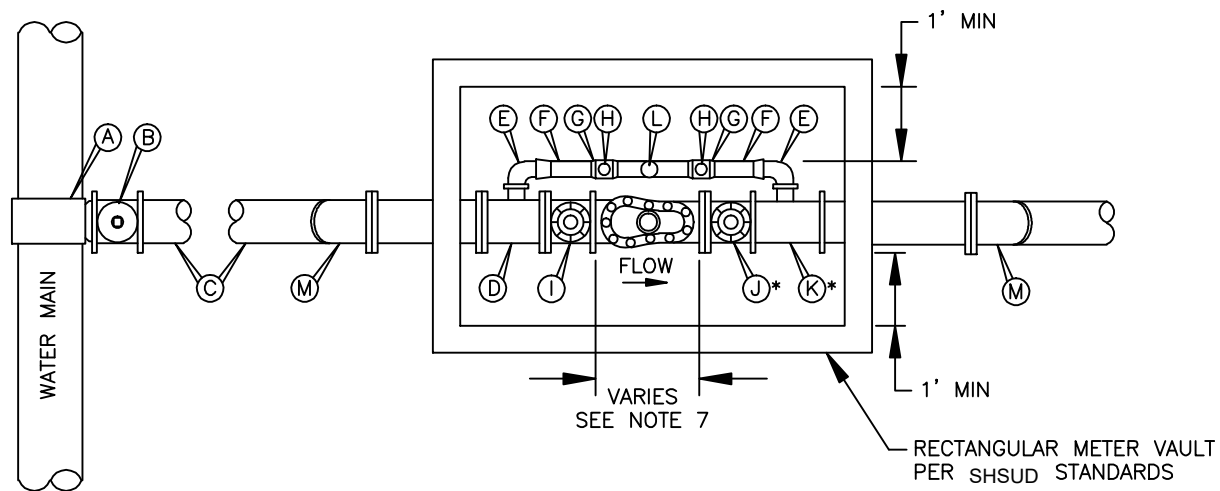
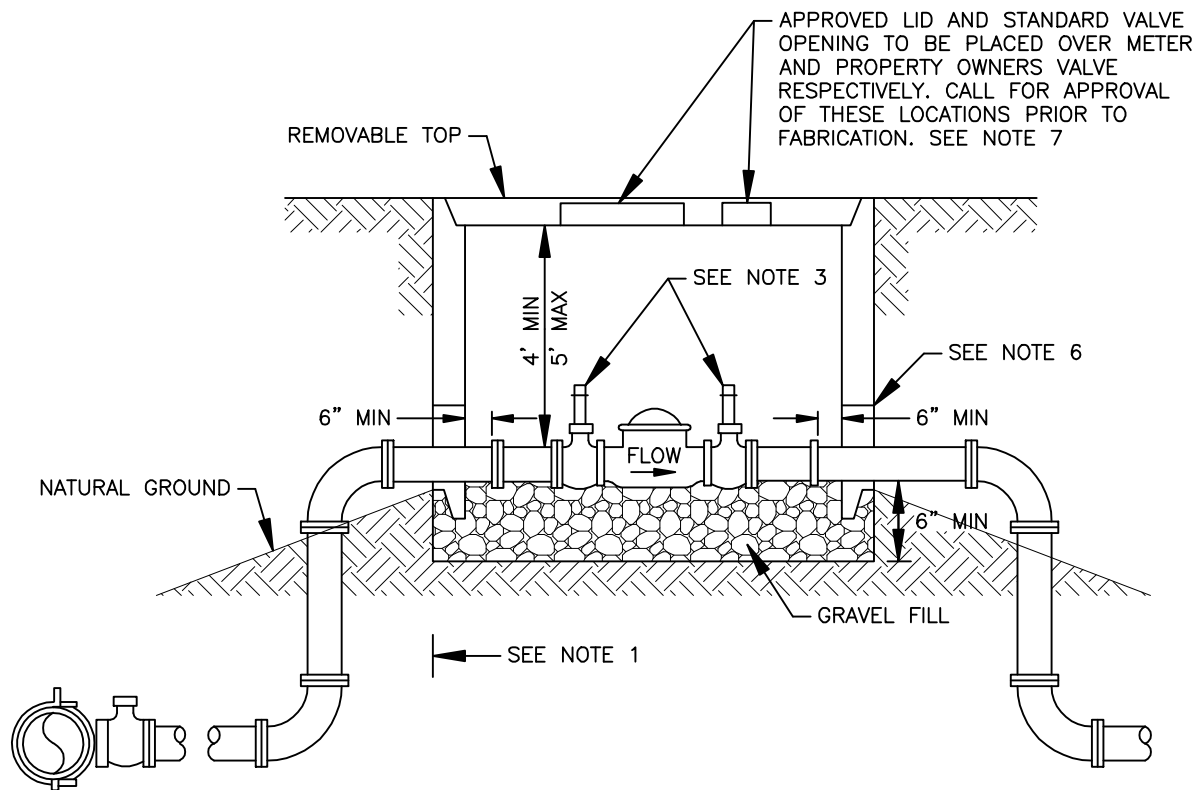

**SPRINGS HILL SPECIAL UTILITY DISTRICT**

**INSTALLATION DETAILS FOR 3", 4" AND 6" COMPOUND METERS ABOVE GND SHEET 1 OF 2**

DATE:  
07/26/2010

REVISIONS:

STANDARD NO.  
WA-31

MATERIALS:

- A. APPROVED TAPPING SLEEVE
  - B. TAPPING VALVE (GATE) IRON BODY WITH M.J. OUTLET
  - C. DUCTILE IRON OR CAST IRON PIPE NOT LESS THAN 4" DIAMETER
  - D, TAPPED CAST IRON TEE – M.J. x SPIGOT
  - \*E. COPPER TO MALE IRON PIPE QUARTER BEND COUPLINGS.
  - F. 2" COPPER PIPE
  - G. COPPER TO MALE IRON PIPE FITTING
  - H. 2" BRASS BALL VALVE
  - I. SHUT OFF VALVE (GATE) CAST IRON MIN 4" FLANGED x M.J.
  - \*J. CUSTOMER'S VALVE (GATE) CAST IRON FLANGED
  - \*K. TAPPED CAST IRON TEE
  - L. METER ON 2" COPPER BY-PASS LINE
  - M. 90' BEND
  - \* VALVE AND FITTING TO BE FURNISHED AND INSTALLED BY CUSTOMER.
- ITEMS D & K MAY BE LOCATED OUTSIDE THE BOX

NOTES:

- 1. BOX MUST BE BEHIND CURB AND/OR WALK AND OUT OF VEHICULAR TRAFFIC.
- 2. PIPE AND FITTINGS TO BE DUCTILE IRON OR CAST IRON EXCEPT AS NOTED. NO PLASTIC PIPE. NO SOLDERED JOINTS.
- 3. NO RISING STEM OR WHEEL OPERATED VALVES EXCEPT ON 2" BY-PASS VALVES.
- 4. ROD RESTRAINT IS REQUIRED AT ALL MECHANICAL OR PUSH ON TYPE JOINTS.
- 5. TOP OF BOX MUST BE 1" ABOVE GROUND OR FLUSH WITH PAVEMENT SURFACE.
- 6. METER BOX TO BE SET AFTER METER IS INSTALLED. SIDE NOTCHES IN BOX TO BE FILLED WITH MORTAR AFTER INSTALLATION OF PIPE.
- 7. CONTACT SHSUD FOR METER LENGTH, APPROVED TYPE OF LID AND LOCATION OF OPENINGS IN TOP OF BOX.
- 8. ANY WORK BY CUSTOMER ON THE CITY SIDE OF THE METER REQUIRES PLANS BY A TEXAS REGISTERED/LICENSED PROFESSIONAL ENGINEER.
- 9. WHERE THERE IS A LOOPED SYSTEM WITH MORE THAN ONE METER, APPROVED CHECK VALVES SHALL BE INSTALLED DOWNSTREAM OF THE PROPERTY OWNERS GATE VALVE (J) AT EACH METER. BACKFLOW PREVENTERS MAY BE REQUIRED WITHIN THE SYSTEM BY THE BUILDING INSPECTION DEPARTMENT.

**SPRINGS HILL SPECIAL UTILITY DISTRICT**

**INSTALLATION DETAILS FOR 3", 4" AND 6"  
COMPOUND METERS ABOVE GND SHEET 2 OF 2**

DATE:  
07/26/2010

REVISIONS:

STANDARD NO.  
WA-31



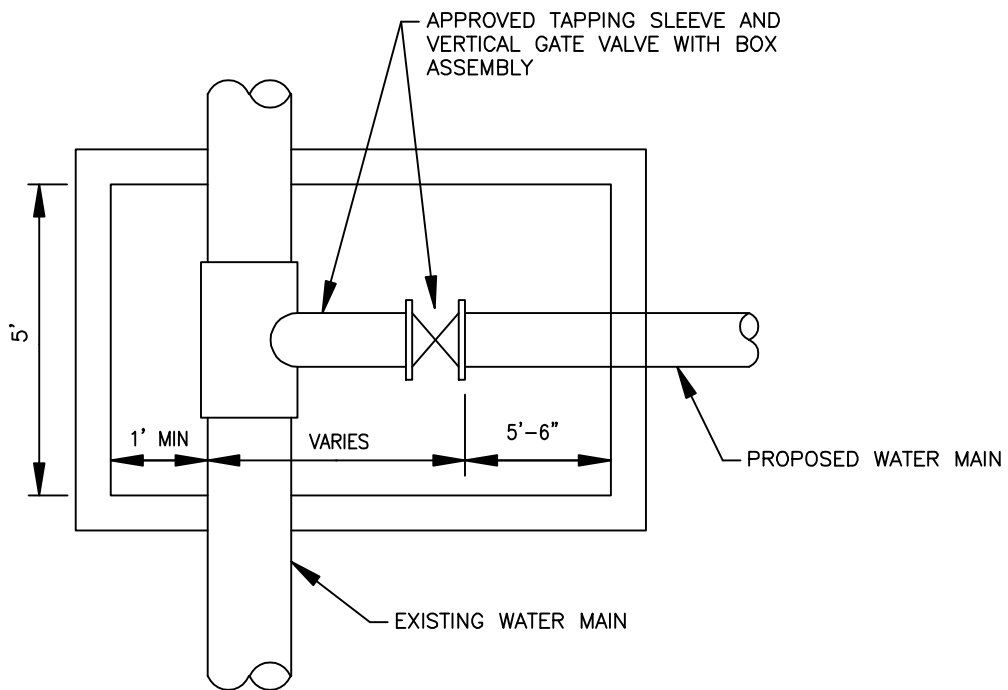

NOTE:

1. NO SIZE ON SIZE ALLOWED, MAKE WET CONNECTION.

**SPRINGS HILL SPECIAL UTILITY DISTRICT**

**MINIMUM EXCAVATION CLEARANCE FOR  
INSTALLATION OF PRESSURE TAP DETAIL**

DATE:  
07/26/2010

REVISIONS:

STANDARD NO.  
WA-32

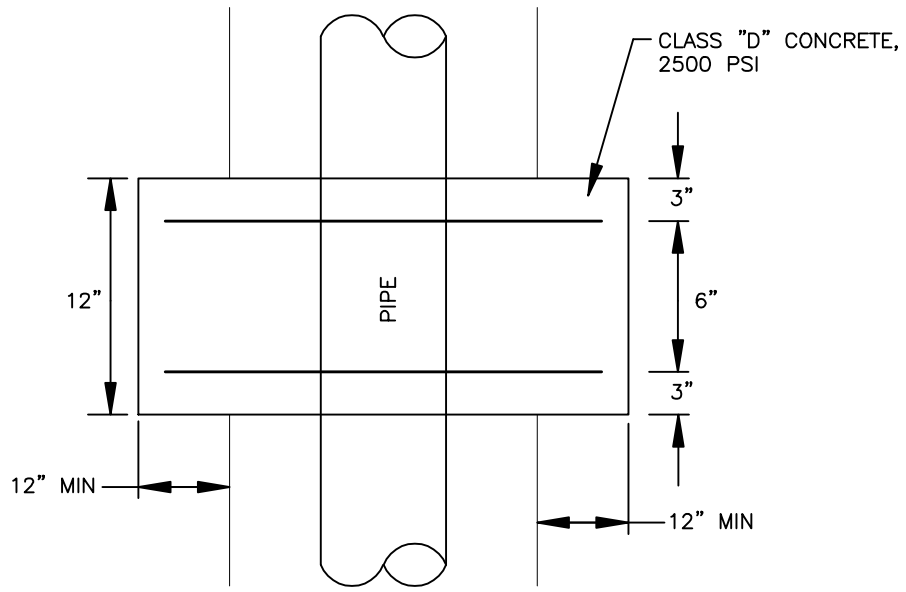

**TOP VIEW**

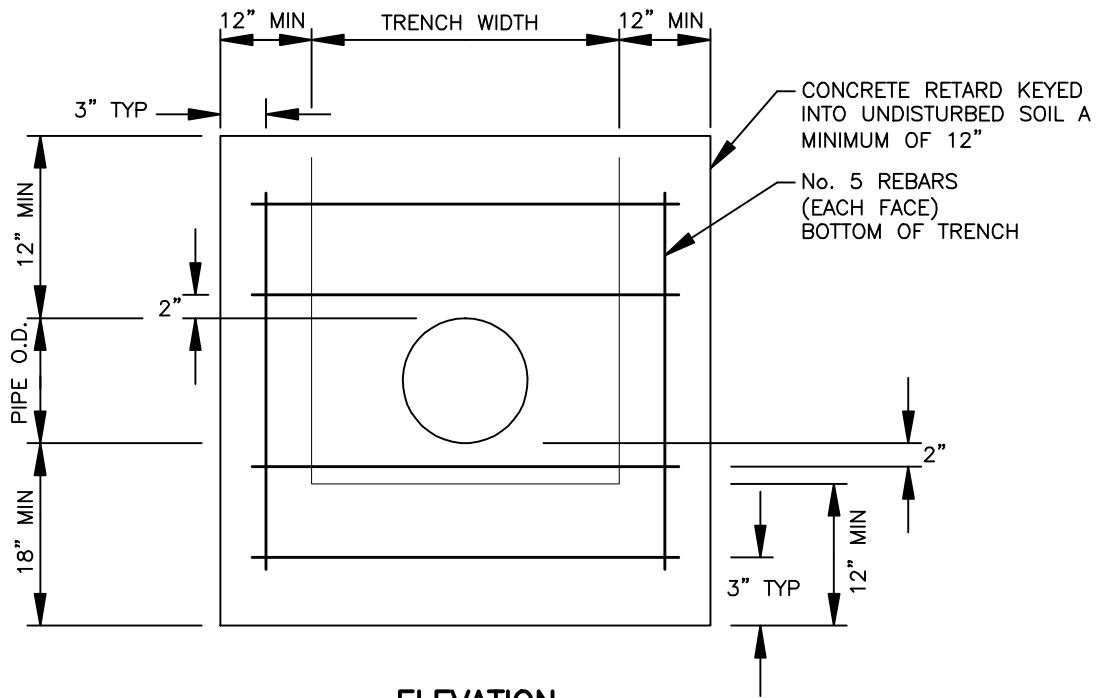

**ELEVATION**

NOTE:

1. RETARDS ARE TO BE USED AT ALL GRADES 10 PERCENT OR OVER.  
(MINIMUM 20 FOOT SPACING)

**SPRINGS HILL SPECIAL UTILITY DISTRICT**

**CONCRETE RETARD**

DATE:  
07/26/2010

REVISIONS:

STANDARD NO.  
WA-33

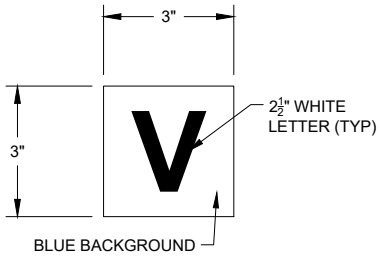
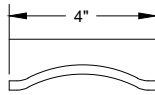

**DECAL  
DETAIL**



**METER**



**VALVES**

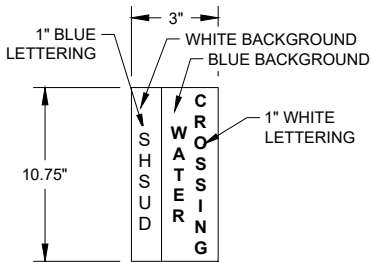

**WATER CROSSING**



**AIR RELEASE VALVE**

**DECALS**

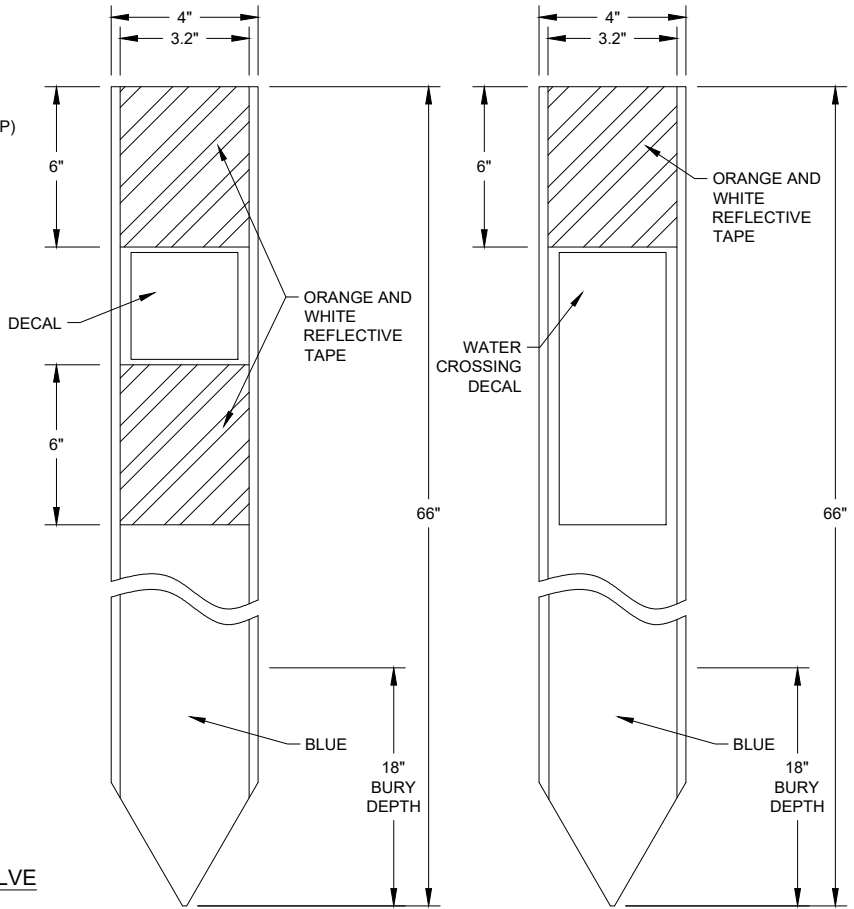

**MARKER  
DETAIL**

**NOTES:**

1. MARKERS SHALL BE 66" COMPOSITE POSTS SIMILAR TO RHINO FIBERCURVE COMPOSITE MARKER POST.
2. MARKERS SHALL BE PLACED AT ALL GATE VALVES, FLUSHING VALVES, & AIR RELEASE VALVES PER ITEM DETAIL.
3. MARKERS SHALL BE PLACED AT WATER METERS AS SPECIFIED ON PLANS
4. PIPELINE MARKERS SHALL BE PLACED ON R.O.W./FENCE LINE AT ALL ROAD CROSSINGS.

**SPRINGS HILL SPECIAL UTILITY DISTRICT**

**WATER LINE MARKER**

DATE:  
07/26/2010

REVISIONS:  
08/05/2021

STANDARD NO.  
WA-34

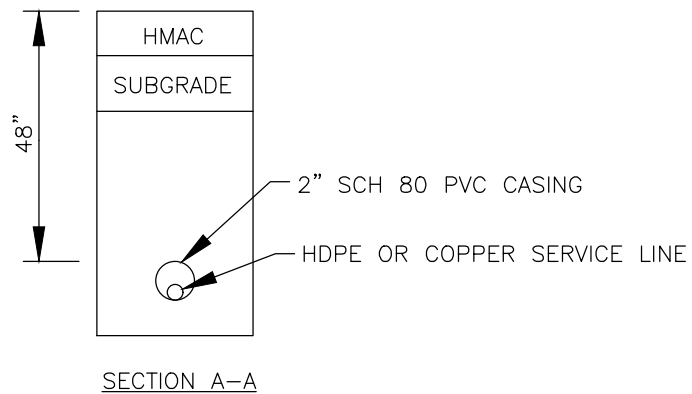
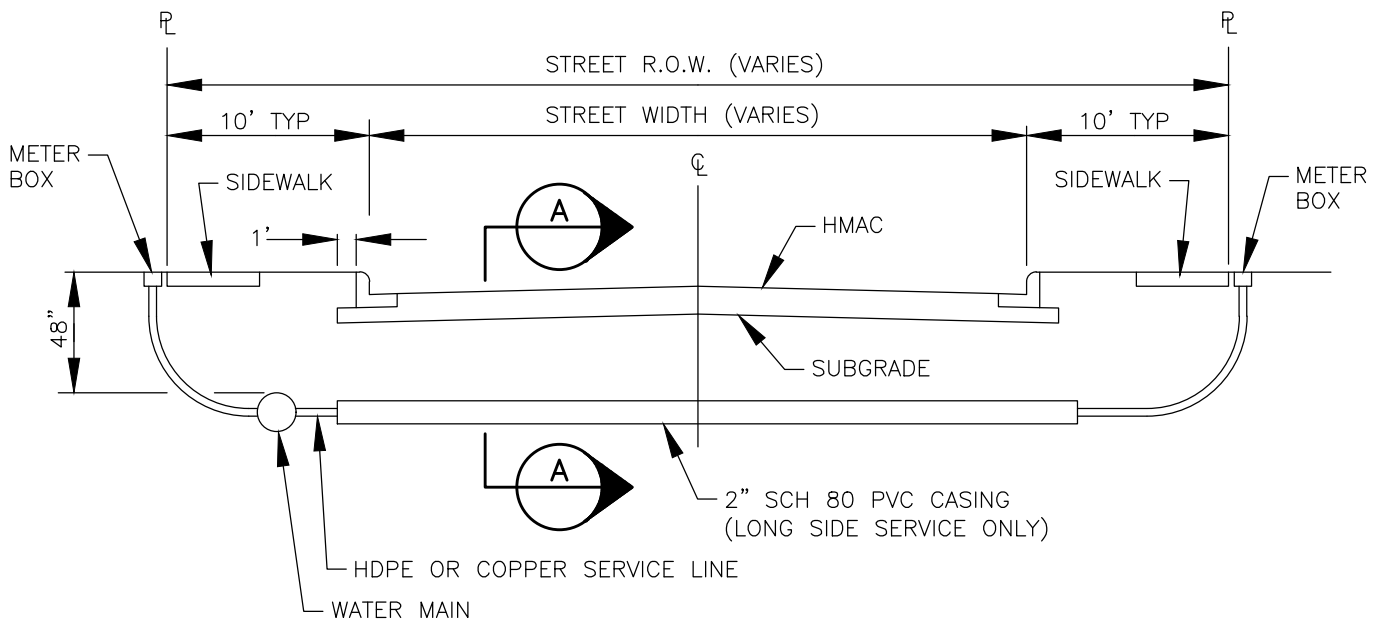

**SPRINGS HILL SPECIAL UTILITY DISTRICT**

**P.E. WATER SERVICE CASING**

DATE:  
07/26/2010

REVISIONS:  
03/15/2022

STANDARD NO.  
WA-35

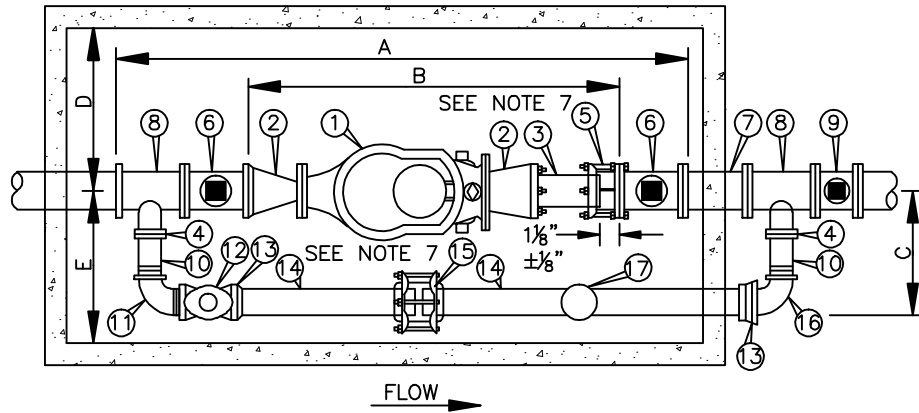

PLAN VIEW

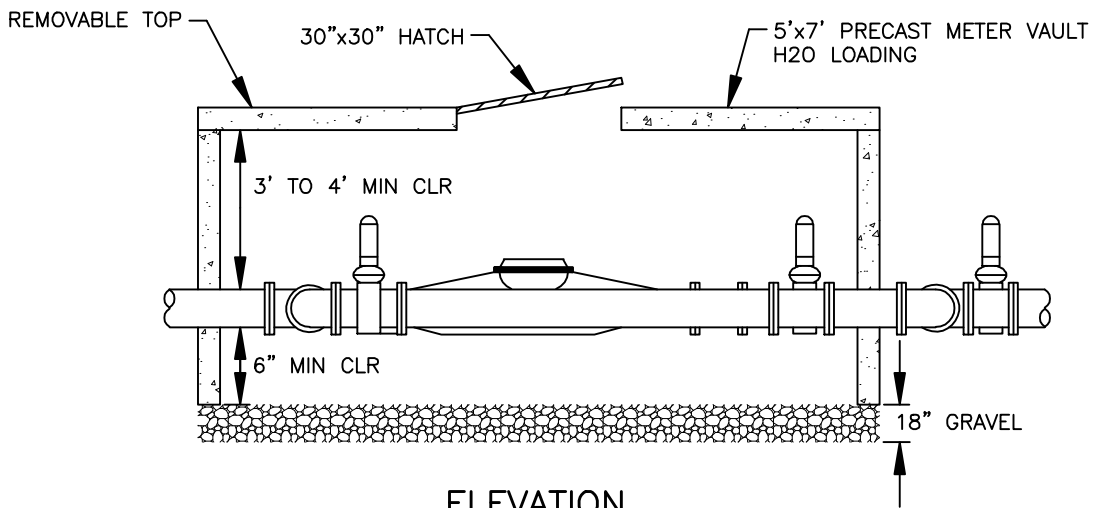

ELEVATION

No	NAME	LENGTH
A	OVERALL LENGTH	76"
B	METER + SPOOL + FCA	44½"
C	CENTERLINE OF MAIN TO OUTSIDE OF BYPASS	15"
D	CENTERLINE OF MAIN TO INSIDE OF VAULT	30"
E	CENTERLINE OF MAIN TO INSIDE OF VAULT	30"

**SPRINGS HILL SPECIAL UTILITY DISTRICT**

**3" METER INSTALATION  
SHT 1 OF 2**

DATE:  
08/12/2010

REVISIONS:

STANDARD NO.  
WA-36

No	NAME	LENGTH
1	3" METER	*17"
2	4"x3" FLANGED REDUCER	7"
3	4" FLANGED x PLAIN END	12"
4	4" COMPANION FLANGE	
5	4" FLANGED COUPLING ADAPTER	5"
6	4" GATE VALVE SQUARE NUT	9"
7	4" FLANGED SPOOL	12" MIN
8	4"x4"x2" FLANGED TEE	13"
9	PROPERTY OWNER'S 4" GATE VALVE SQUARE NUT	9"
10	2"x8" BRASS NIPPLE	8"
11	2" STREET ELBOW 90°	
12	2" BRASS GATE VALVE	
13	COPPER TO IRON PIPE FITTING	
14	2" COPPER OR BRASS PIPE	
15	2" COUPLING	
16	2" ELBOW 90° BRASS	
17	BYPASS METER (SIZE PER SHWSC)	

\* DIMENSIONS SUBJECT TO CHANGE. CHECK WITH INSPECTOR

NOTES:

1. PIPE AND METER SIZE SHALL BE AS DETERMINED BY OWNER. APPROVAL BY SHSUD AND FIRE DEPARTMENT. PLANS MUST BE PREPARED BY A LICENSED ENGINEER IF INSTALLATION IN RIGHT-OF-WAY IS BY OTHER THAN CITY FORCES.
2. METER VAULT MUST BE BEHIND CURB AND/OR WALK AND OUT OF VEHICULAR TRAFFIC.
3. MAIN LINE AND BYPASS VALVES WILL BE RESILIENT SEAT TYPE WITH CORROSION RESISTANT FUSION BANDED EPOXY COATING INSIDE AND OUTSIDE, NON-RISING STEM. MAIN LINE VALVES SHALL HAVE SQUARE OPERATING NUTS. BYPASS VALVE WILL HAVE A HANDWHEEL. PROPERTY OWNER'S VALVE MUST BE LOCATED OUTSIDE THE SHSUD METER VAULT.
4. APPROVAL WILL BE NEEDED IF HEIGHT OF VAULT EXCEEDS 72". METER MUST BE MODIFIED TO READ FROM TOP OF VAULT.
5. HATCH OPENING WILL BE 30"x30".
6. IRON PIPE TAPPING SLEEVE IN STREET RIGHT-OF-WAY SHALL BE IMBEDDED IN GRANULAR MATERIALS AS REQUIRED BY SHSUD STANDARD SPECIFICATIONS. BACKFILL ABOVE GRANULAR BEDDING AS REQUIRED.
7. DOUBLE HARNESS MJ WITH TIE RODS. ALL OTHER FITTINGS INSIDE VAULT WILL BE FLANGED.
8. CONTACT SHSUD OFFICE PRIOR TO INSTALLATION OF COMPOUND METERS FOR PROPER DOMESTIC DEMANDS.
9. NOTCHES WHERE PIPING GOES THROUGH VAULT SHALL BE FILLED WITH MORTAR.
10. THE TOP OF THE METER VAULT SHALL BE AT AN ELEVATION SUCH THAT THE SURROUNDING GROUND SLOPES AWAY FROM THE VAULT.

**SPRINGS HILL SPECIAL UTILITY DISTRICT**

**3" METER INSTALATION  
SHT 2 OF 2**

DATE:  
08/12/2010

REVISIONS:

STANDARD NO.  
WA-36

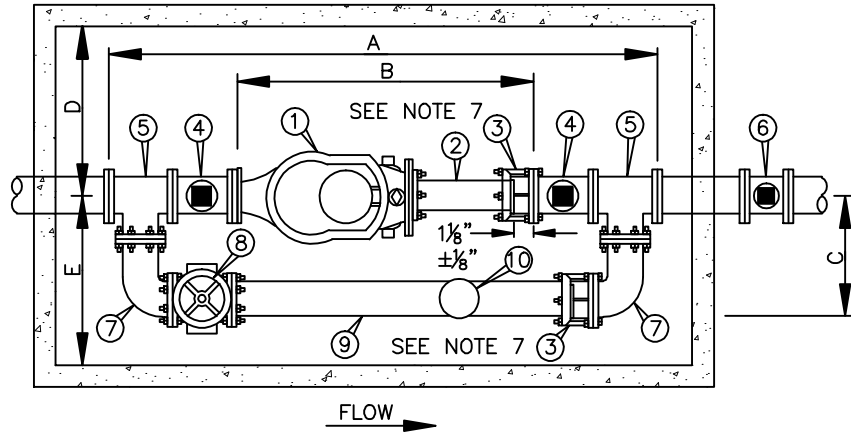

**PLAN VIEW**

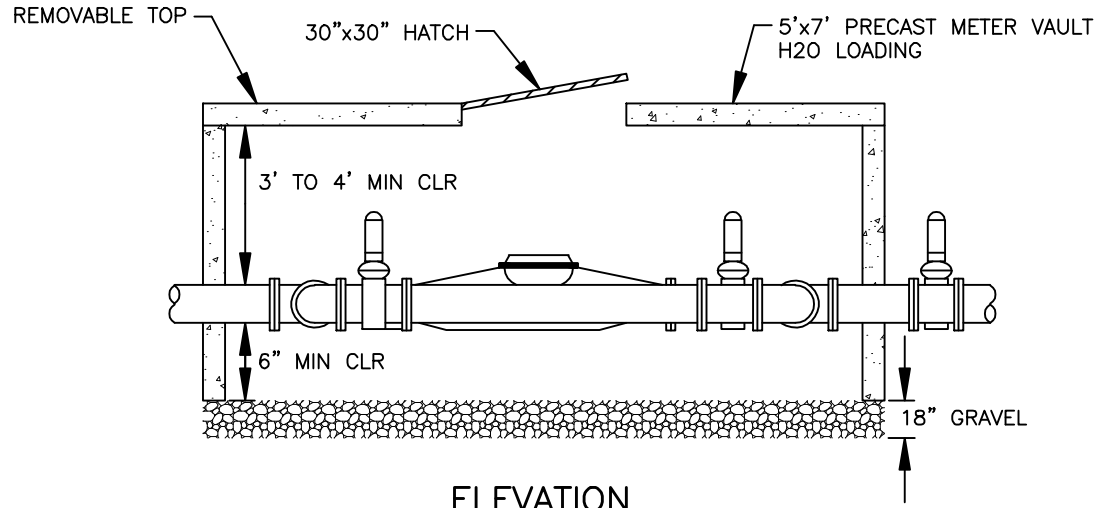

**ELEVATION**

No	NAME	LENGTH
A	OVERALL LENGTH	79"
B	METER + NIPPLE + FCA	34½"
C	CENTERLINE OF MAIN TO OUTSIDE OF BYPASS	17½"
D	CENTERLINE OF MAIN TO INSIDE OF VAULT	30"
E	CENTERLINE OF MAIN TO INSIDE OF VAULT	30"

**SPRINGS HILL SPECIAL UTILITY DISTRICT**

**4" METER INSTALATION  
SHT 1 OF 2**

DATE:  
08/12/2010

REVISIONS:

STANDARD NO.  
WA-37

No	NAME	LENGTH
1	4" METER	*21"
2	4" FLANGED x PLAIN END	12"
3	4" FLANGED COUPLING ADAPTER	5"
4	4" GATE VALVE SQUARE NUT	9"
5	4"x4"x4" FLANGED TEE	13"
6	PROPERTY OWNER'S 4" GATE VALVE SQUARE NUT	9"
7	4" FLANGED LONG RADIUS ELBOW 90°	
8	4" BYPASS GATE VALVE WITH HANDWHEEL	9"
9	4" BYPASS DUCTILE IRON PIPE	
10	BYPASS METER (SIZE PER SHWSC)	

\* DIMENSIONS SUBJECT TO CHANGE. CHECK WITH INSPECTOR

NOTES:

1. PIPE AND METER SIZE SHALL BE AS DETERMINED BY OWNER. APPROVAL BY SHSUD AND FIRE DEPARTMENT. PLANS MUST BE PREPARED BY A LICENSED ENGINEER IF INSTALLATION IN RIGHT-OF-WAY IS BY OTHER THAN CITY FORCES.
2. METER VAULT MUST BE BEHIND CURB AND/OR WALK AND OUT OF VEHICULAR TRAFFIC.
3. MAIN LINE AND BYPASS VALVES WILL BE RESILIENT SEAT TYPE WITH CORROSION RESISTANT FUSION BANDED EPOXY COATING INSIDE AND OUTSIDE, NON-RISING STEM. MAIN LINE VALVES SHALL HAVE SQUARE OPERATING NUTS. BYPASS VALVE WILL HAVE A HANDWHEEL. PROPERTY OWNER'S VALVE MUST BE LOCATED OUTSIDE THE SHSUD: METER VAULT.
4. APPROVAL WILL BE NEEDED IF HEIGHT OF VAULT EXCEEDS 72". METER MUST BE MODIFIED TO READ FROM TOP OF VAULT.
5. HATCH OPENING WILL BE 30"x30".
6. IRON PIPE TAPPING SLEEVE IN STREET RIGHT-OF-WAY SHALL BE IMBEDDED IN GRANULAR MATERIALS AS REQUIRED BY SHSUD STANDARD SPECIFICATIONS. BACKFILL ABOVE GRANULAR BEDDING AS REQUIRED.
7. DOUBLE HARNESS MJ WITH TIE RODS. ALL OTHER FITTINGS INSIDE VAULT WILL BE FLANGED.
8. CONTACT SHSUD OFFICE PRIOR TO INSTALLATION OF COMPOUND METERS FOR PROPER DOMESTIC DEMANDS.
9. NOTCHES WHERE PIPING GOES THROUGH VAULT SHALL BE FILLED WITH MORTAR.
10. THE TOP OF THE METER VAULT SHALL BE AT AN ELEVATION SUCH THAT THE SURROUNDING GROUND SLOPES AWAY FROM THE VAULT.

**SPRINGS HILL SPECIAL UTILITY DISTRICT**

**4" METER INSTALATION  
SHT 2 OF 2**

DATE:  
08/12/2010

REVISIONS:

STANDARD NO.  
WA-37



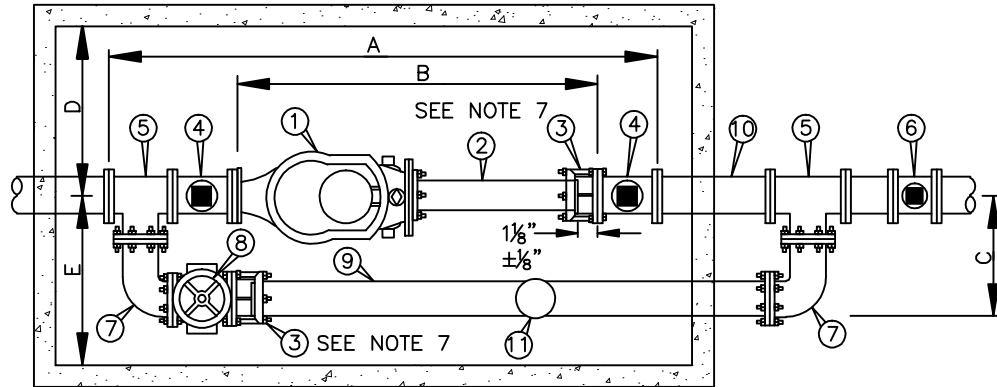

FLOW →

PLAN VIEW

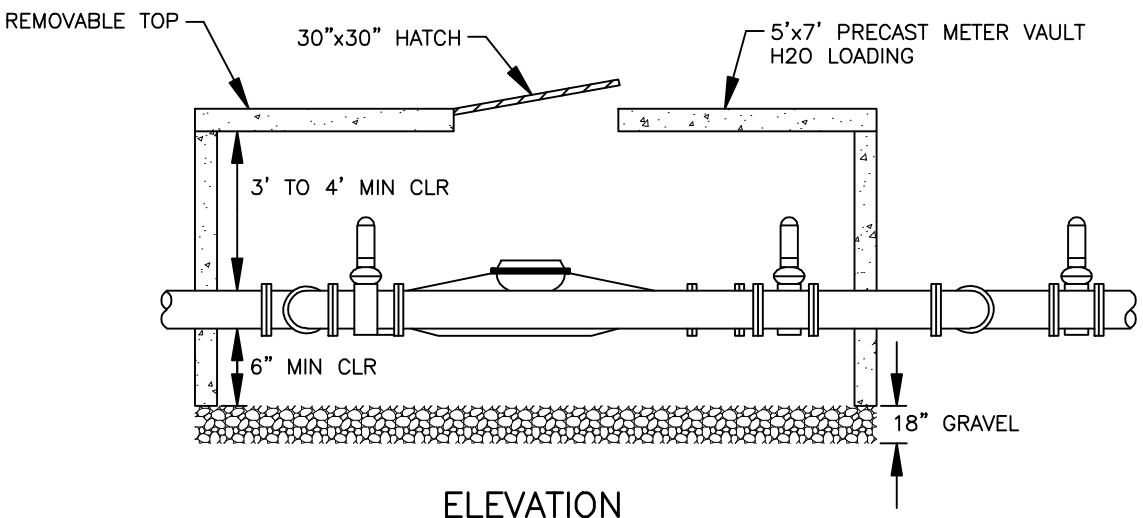

ELEVATION

No	NAME	LENGTH
A	OVERALL LENGTH	74 <sup>3</sup> / <sub>4</sub> "
B	METER + NIPPLE + FCA	37 <sup>1</sup> / <sub>2</sub> "
C	CENTERLINE OF MAIN TO OUTSIDE OF BYPASS	17 <sup>1</sup> / <sub>2</sub> "
D	CENTERLINE OF MAIN TO INSIDE OF VAULT	30"
E	CENTERLINE OF MAIN TO INSIDE OF VAULT	30"

**SPRINGS HILL SPECIAL UTILITY DISTRICT**

**6" METER INSTALATION  
SHT 1 OF 2**

DATE:  
08/12/2010

REVISIONS:

STANDARD NO.  
WA-38

No	NAME	LENGTH
1	6" METER	*24"
2	6" FLANGED x PLAIN END	12"
3	6" FLANGED COUPLING ADAPTER	5"
4	6" GATE VALVE SQUARE NUT	10½"
5	6"x6"x6" FLANGED TEE	5"
6	PROPERTY OWNER'S 6" GATE VALVE SQUARE NUT	10½"
7	6" FLANGED ELBOW 90°	
8	6" BYPASS GATE VALVE WITH HANDWHEEL	10½"
9	6" BYPASS DUCTILE IRON PIPE	
10	6" FLANGED SPOOL	
11	BYPASS METER (SIZE PER SHWSC)	

\* DIMENSIONS SUBJECT TO CHANGE. CHECK WITH INSPECTOR

NOTES:

1. PIPE AND METER SIZE SHALL BE AS DETERMINED BY OWNER. APPROVAL BY SHSUD AND FIRE DEPARTMENT. PLANS MUST BE PREPARED BY A LICENSED ENGINEER IF INSTALLATION IN RIGHT-OF-WAY IS BY OTHER THAN CITY FORCES.
2. METER VAULT MUST BE BEHIND CURB AND/OR WALK AND OUT OF VEHICULAR TRAFFIC.
3. MAIN LINE AND BYPASS VALVES WILL BE RESILIENT SEAT TYPE WITH CORROSION RESISTANT FUSION BANDED EPOXY COATING INSIDE AND OUTSIDE, NON-RISING STEM. MAIN LINE VALVES SHALL HAVE SQUARE OPERATING NUTS. BYPASS VALVE WILL HAVE A HANDWHEEL. PROPERTY OWNER'S VALVE MUST BE LOCATED OUTSIDE THE SHSUD METER VAULT.
4. APPROVAL WILL BE NEEDED IF HEIGHT OF VAULT EXCEEDS 72". METER MUST BE MODIFIED TO READ FROM TOP OF VAULT.
5. HATCH OPENING WILL BE 30"x30".
6. IRON PIPE TAPPING SLEEVE IN STREET RIGHT-OF-WAY SHALL BE IMBEDDED IN GRANULAR MATERIALS AS REQUIRED BY SHSUD STANDARD SPECIFICATIONS. BACKFILL ABOVE GRANULAR BEDDING AS REQUIRED.
7. DOUBLE HARNESS MJ WITH TIE RODS. ALL OTHER FITTINGS INSIDE VAULT WILL BE FLANGED.
8. CONTACT SHSUD OFFICE PRIOR TO INSTALLATION OF COMPOUND METERS FOR PROPER DOMESTIC DEMANDS.
9. NOTCHES WHERE PIPING GOES THROUGH VAULT SHALL BE FILLED WITH MORTAR.
10. THE TOP OF THE METER VAULT SHALL BE AT AN ELEVATION SUCH THAT THE SURROUNDING GROUND SLOPES AWAY FROM THE VAULT.

**SPRINGS HILL SPECIAL UTILITY DISTRICT**

**6" METER INSTALATION  
SHT 2 OF 2**

DATE:  
08/12/2010

REVISIONS:

STANDARD NO.  
WA-38

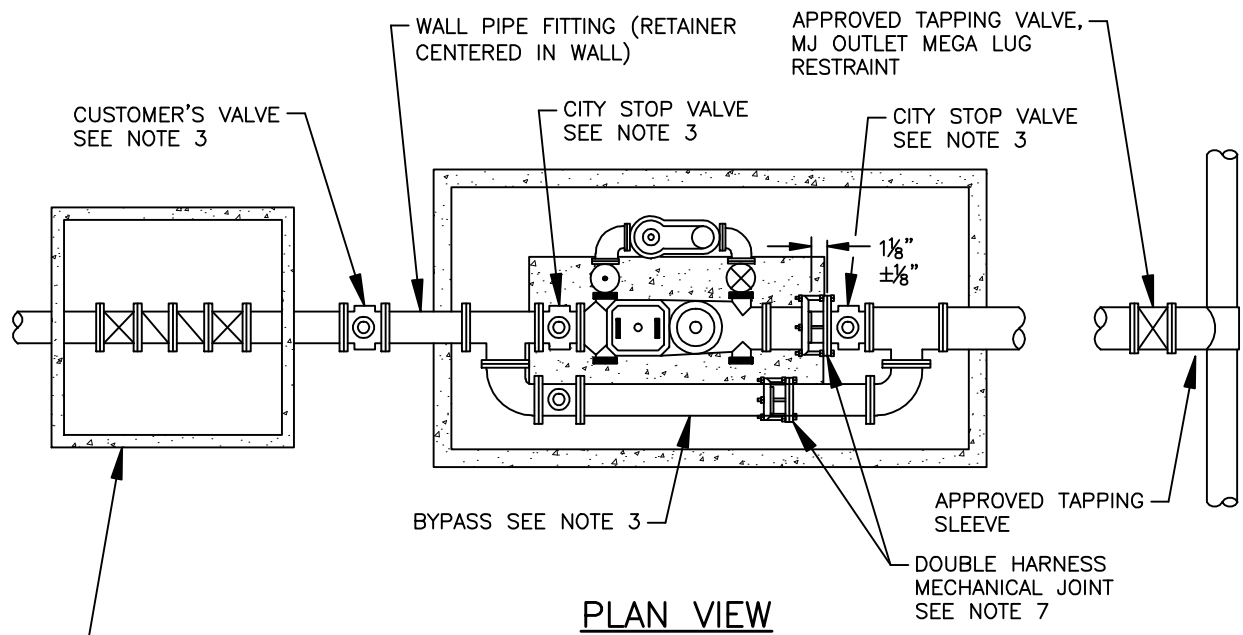

**PLAN VIEW**

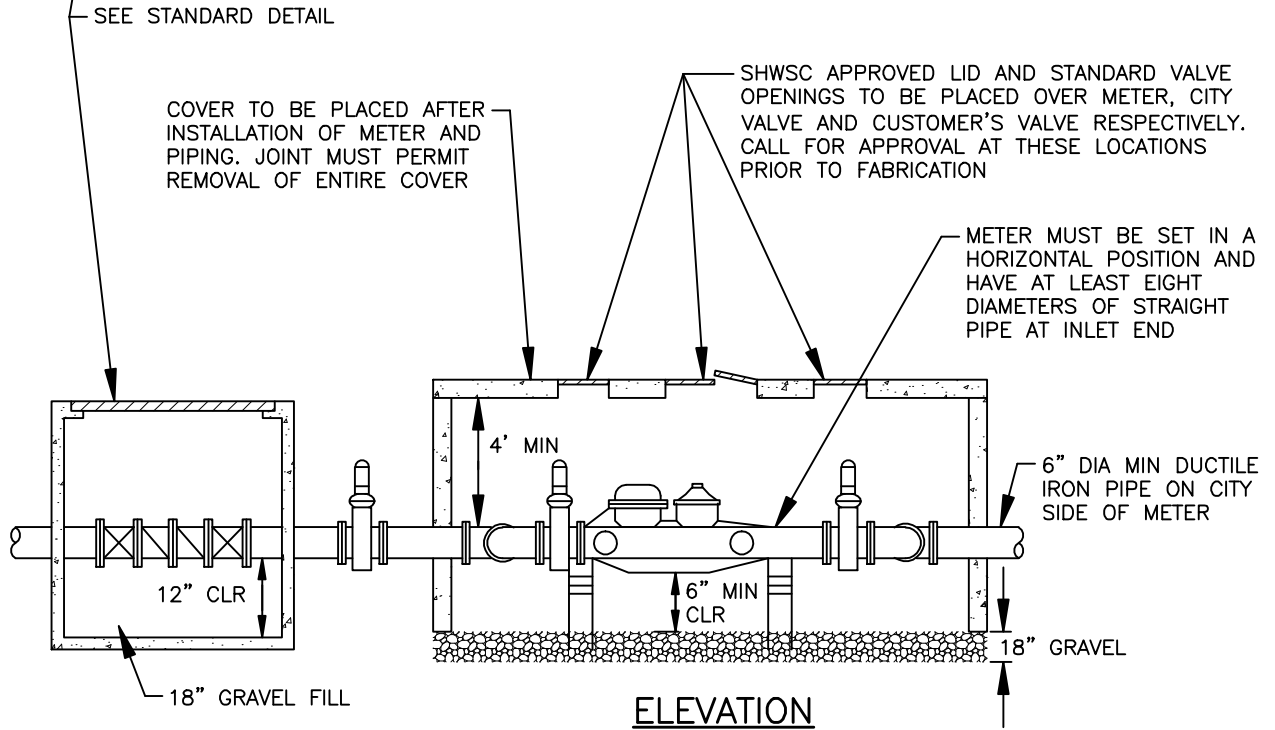

**ELEVATION**

NOTE:  
 LATERAL DRAIN LINES WILL BE REQUIRED IF SURROUNDING CONDITIONS CAUSE WATER TO COLLECT IN THE VAULT

**SPRINGS HILL SPECIAL UTILITY DISTRICT**

**FIRE LINE METER INSTALATION  
 SHT 1 OF 4**

DATE:  
 08/12/2010

REVISIONS:

STANDARD NO.  
 WA-39

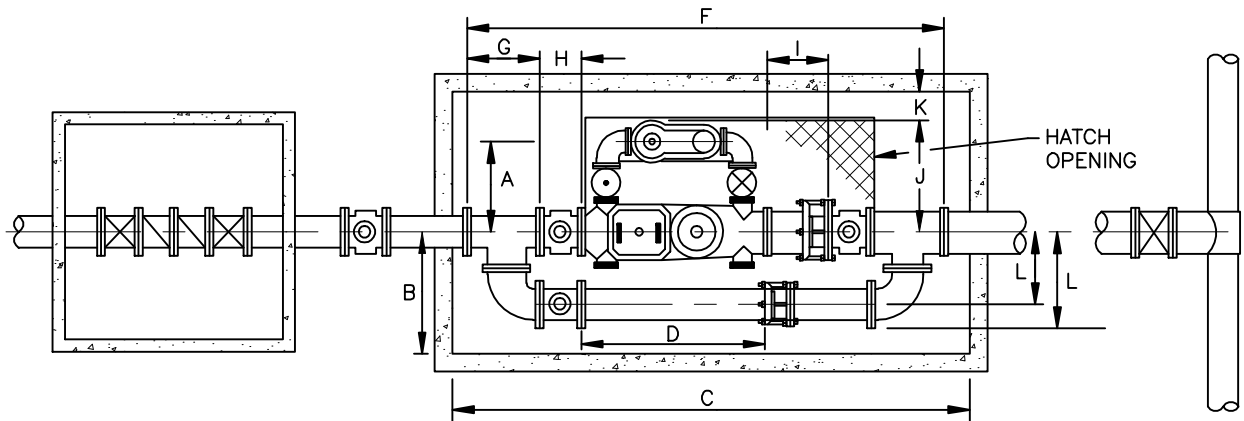

8' x 12' VAULT  
 LOCATION OF 4' x 6'  
 HATCH OPENING FOR  
 6"x3"x3/4" METER

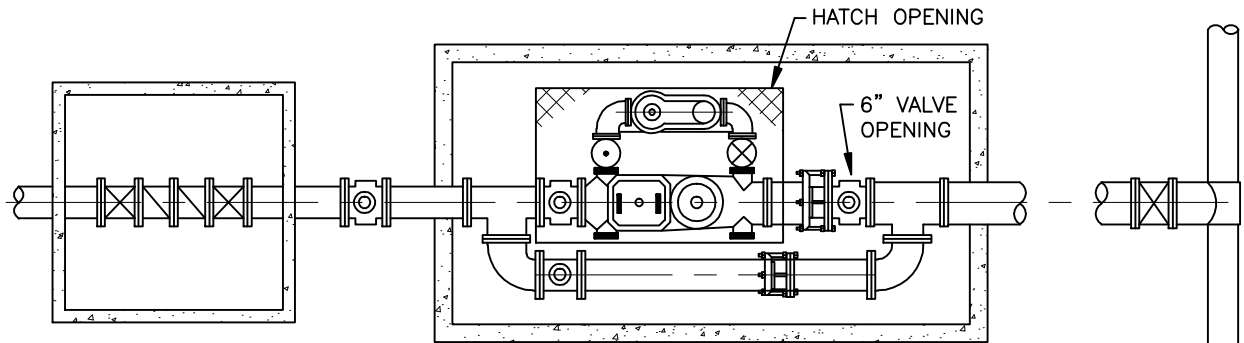

10' x 12' VAULT  
 LOCATION OF 4' x 6'  
 HATCH OPENING FOR  
 8"x4"x1" METER

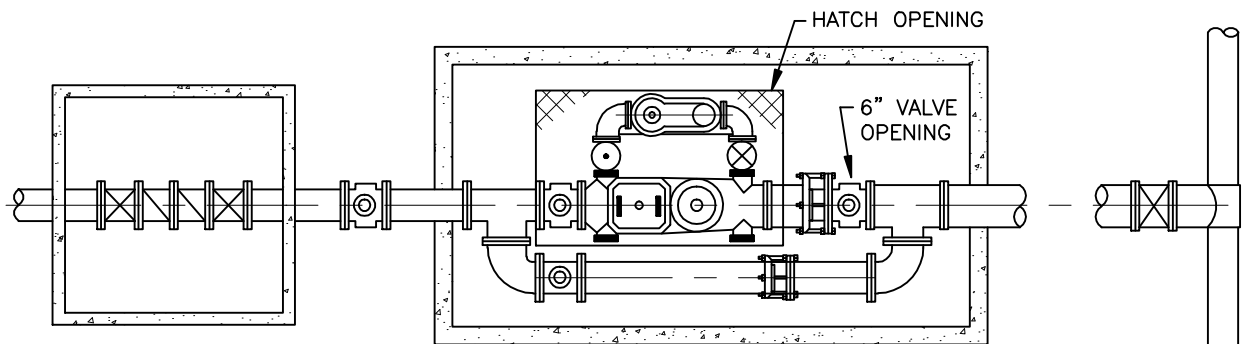

15' x 10' VAULT  
 LOCATION OF 4' x 6'  
 HATCH OPENING FOR  
 10"x10"x6"x1 1/2" AND  
 10"x12"x6"x1 1/2" METERS

**SPRINGS HILL SPECIAL UTILITY DISTRICT**

**FIRE LINE METER INSTALATION  
 SHT 2 OF 4**

DATE:  
 08/12/2010

REVISIONS:

STANDARD NO.  
 WA-39

METER AND BOX DIMENSIONS (INCHES)

WATER METER SIZE	A	B	C	D	E	F	G	H	I	J	K	L
6 x 3	60	36	144	45	15	114	16	10½	13	27	33	22
8 x 4	72	48	144	53	8	127	18	11½	13	33	39	25
10 x 10 x 6	72	48	180	68	13	154	22	13	13	42	30	30
10 x 12 x 6	72	48	180	68	10	160	24	14	13	42	30	34

WATER METER SIZE	SIZE OF BY-PASS	BY-PASS VALVE W/HANDWHEEL	MAIN LINE VALVE WITH SQUARE OPERATING NUT
6 x 3	6"	6"	6"
8 x 4	8"	8"	8"
10 x 10 x 6	10"	10"	10"
10 x 12 x 6	12"	12"	12"

MINIMUM NUMBER OF TIE RODS

PIPE SIZE INCHES	WORKING PRESSURE PSI (A)					
	50	75	100	125	150	200
3, 4, & 6	2	2	2	2	2	2
8	2	2	2	2	4	4
10	2	2	4	4	4	6
12	2	4	4	4	6	6
14	2	4	4	6	8	10
16	4	4	6	8	8	12
18	4	6	8	10	10	(b)
20	4	6	8	10	12	(b)
24	6	10	12	16	(b)	(b)
30	6	8	10	12	14	18
36	8	10	14	16	20	(b)
42	6	8	12	14	16	22
48	8	10	14	18	20	28

NOTES:

(a) BASED UPON TEST PRESSURE NOT MORE THAN 50% HIGHER THAN WORKING PRESSURE.

(b) REQUIRED NUMBER EXCEEDS NUMBER OF HOLES IN STANDARD MECHANICAL JOINT. USE OTHER METHODS OF HARNESSING.

**SPRINGS HILL SPECIAL UTILITY DISTRICT**

**FIRE LINE METER INSTALATION  
SHT 3 OF 4**

DATE:  
08/12/2010

REVISIONS:

STANDARD NO.  
WA-39

NOTES:

1. PIPE AND METER SIZE SHALL BE AS DETERMINED BY OWNER. APPROVAL BY SHSUD AND FIRE DEPARTMENT. PLANS MUST BE PREPARED BY A LICENSED ENGINEER IF INSTALLATION IN RIGHT-OF-WAY IS BY OTHER THAN CITY FORCES.
2. METER VAULT MUST BE BEHIND CURB AND/OR WALK AND OUT OF VEHICULAR TRAFFIC.
3. MAIN LINE AND BYPASS VALVES WILL BE RESILIENT SEAT TYPE WITH CORROSION RESISTANT FUSION BANDED EPOXY COATING INSIDE AND OUTSIDE, NON-RISING STEM. MAIN LINE VALVES SHALL HAVE SQUARE OPERATING NUTS. BYPASS VALVE WILL HAVE A HANDWHEEL. PROPERTY OWNER'S VALVE MUST BE LOCATED OUTSIDE THE SHSUD METER VAULT.
4. APPROVAL WILL BE NEEDED IF HEIGHT OF VAULT EXCEEDS 72". METER MUST BE MODIFIED TO READ FROM TOP OF VAULT.
5. HATCH OPENING WILL BE 4'x6' DOUBLE LEAF. (H2O LOADING REQUIRED)
6. IRON PIPE TAPPING SLEEVE IN STREET RIGHT-OF-WAY SHALL BE IMBEDDED IN GRANULAR MATERIALS AS REQUIRED BY SHSUD STANDARD SPECIFICATIONS. BACKFILL ABOVE GRANULAR BEDDING AS REQUIRED.
7. DOUBLE HARNESS MJ WITH TIE RODS. ALL OTHER FITTINGS INSIDE VAULT WILL BE FLANGED.
8. IF METER VAULT IS TO BE POURED IN PLACE OR PRECAST IF AVAILABLE IN THE PROPER SIZE, CONSTRUCTION PLANS MUST BE PREPARED BY A REGISTERED PROFESSIONAL ENGINEER. (H2O LOADING REQUIRED)
9. NOTCHES WHERE PIPING GOES THROUGH VAULT SHALL BE FILLED WITH MORTAR.
10. THE TOP OF THE METER VAULT SHALL BE AT AN ELEVATION SUCH THAT THE SURROUNDING GROUND SLOPES AWAY FROM THE VAULT.

**SPRINGS HILL SPECIAL UTILITY DISTRICT**

**FIRE LINE METER INSTALATION  
SHT 4 OF 4**

DATE:  
08/12/2010

REVISIONS:

STANDARD NO.  
WA-39

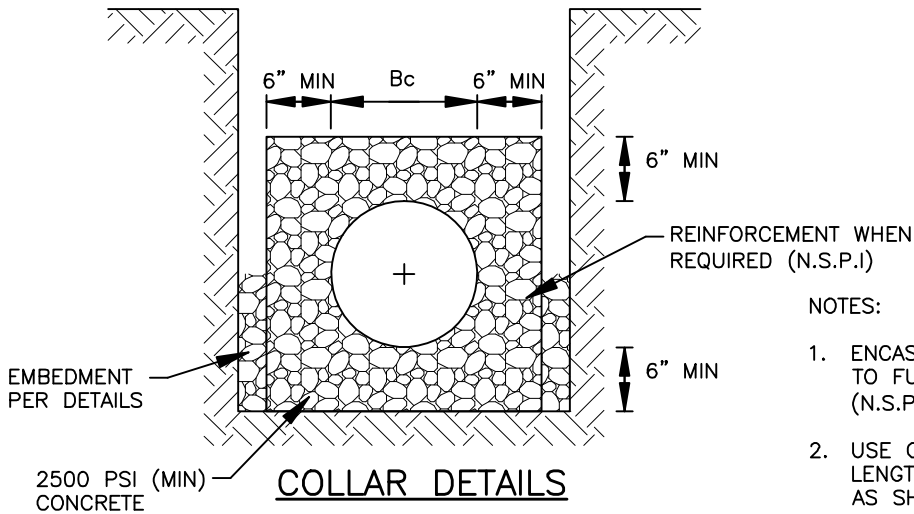
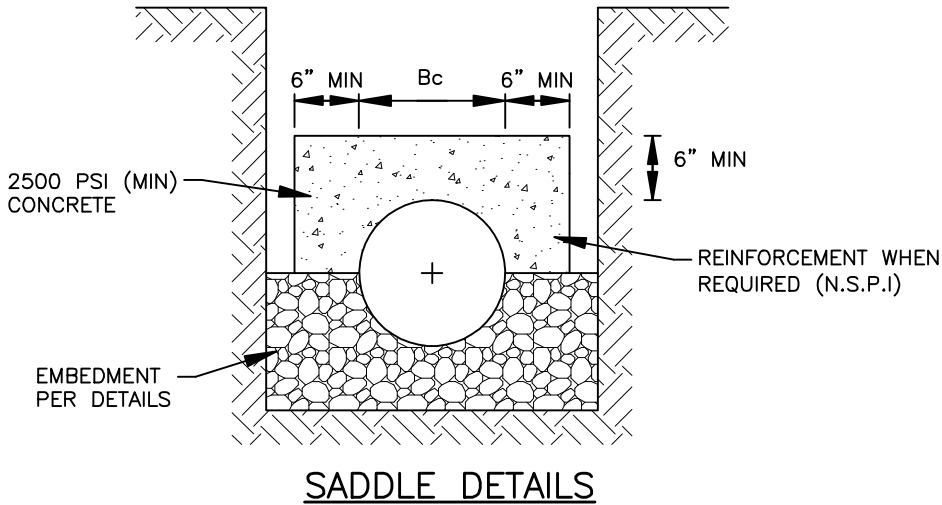
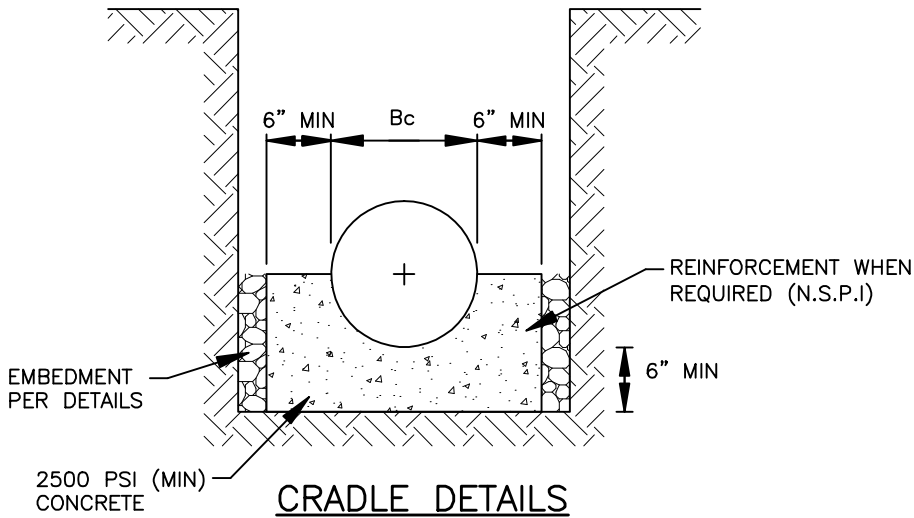

NOTES:

1. ENCASEMENT MAY BE PLACED TO FULL TRENCH WIDTH. (N.S.P.I)
2. USE COLLAR DETAILS FOR FULL LENGTH CONCRETE ENCASEMENT AS SHOWN ON PLANS.

**SPRINGS HILL SPECIAL UTILITY DISTRICT**

**ENCASEMENT**

DATE:  
08/12/2010

REVISIONS:

STANDARD NO.  
WA-40

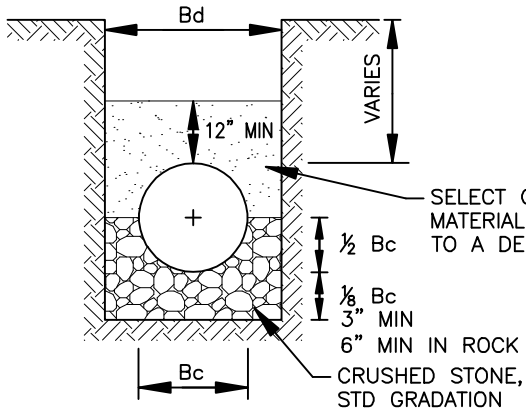

**CLASS "B"**

BEDDING ANGLE 150', LF 1.9, E'=700

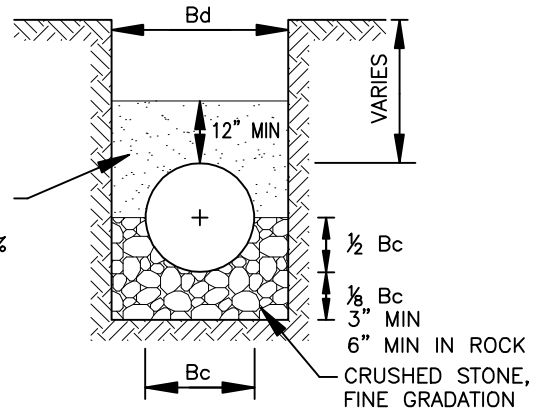

**CLASS "B+"**

BEDDING ANGLE 150', LF 1.9, E'=700

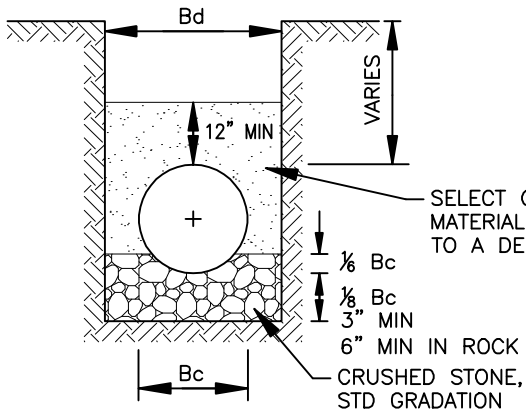

**CLASS "C"**

BEDDING ANGLE 75', LF 1.5, E'=300

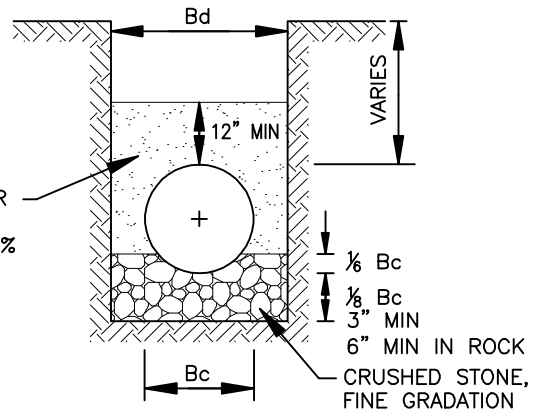

**CLASS "C"**

BEDDING ANGLE 75', LF 1.5, E'=300

**SPRINGS HILL SPECIAL UTILITY DISTRICT**

**EMBEDMENT  
SHT 1 OF 3**

DATE:  
08/12/2010

REVISIONS:

STANDARD NO.  
WA-41



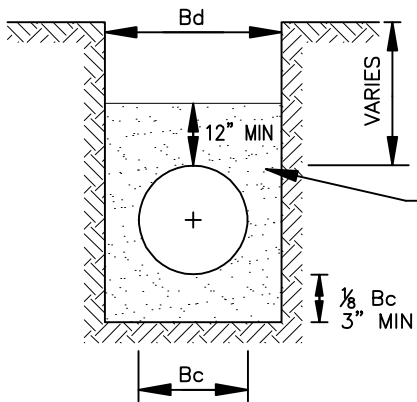

SELECT OR GRANULAR MATERIAL COMPACTED TO A DENSITY OF 90%

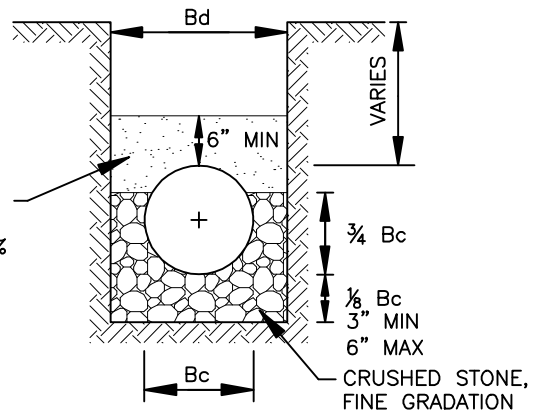

**CLASS "D+"**

**CLASS "F"**

BEDDING ANGLE 30', LF 1.3, E'=200

EMBEDMENT FOR WATER LINES						
TYPE OF PIPE	IN EARTH			IN ROCK		
	0'-8'	8'-16'	>16'	0'-8'	8'-16'	>16'
18" AND SMALLER DUCTILE IRON WATER LINE	D+	C	C	D+	C	B
18" AND LARGER DUCTILE IRON WATER LINE	D+	B	B	D+	B	B
ALL PVC WATER LINE	C+	B+	B+	C+	B+	B+
24" & 30" RCCP	D+	B	B	D+	B	B

NOTES:

1. PIPE EMBEDMENT SHALL CONFORM TO DETAILS SHOWN HEREIN.
2. SECONDARY BACKFILL SHALL EXTEND FROM ABOVE THE EMBEDMENT TO BELOW THE PAVEMENT REPAIR SECTION WITHIN PAVEMENT AREA AND TO BELOW THE TOPSOIL SECTION OUTSIDE PAVEMENT AREAS.
3. SECONDARY BACKFILL SHALL CONSIST OF SELECT MATERIAL INCLUDING GRAVEL, FINE ROCK CUTTINGS, SAND, SANDY LOAM, OR LOAM FREE FROM EXCESSIVE CLAY. ROCK CUTTINGS SHALL HAVE NO DIMENSION GREATER THAN TWO INCHES. TRENCH CUTTINGS MAY BE UTILIZED AS SELECT MATERIAL PROVIDED THE CONDITIONS OF THIS PARAGRAPH ARE MET.
4. SECONDARY BACKFILL SHALL BE MECHANICALLY COMPACTED TO 95% STANDARD PROCTOR DENSITY WITHIN PAVEMENT AREAS AND TO 90% STANDARD PROCTOR DENSITY OUTSIDE PAVEMENT AREAS.

**SPRINGS HILL SPECIAL UTILITY DISTRICT**

**EMBEDMENT  
SHT 2 OF 3**

DATE:  
08/12/2010

REVISIONS:

STANDARD NO.  
WA-41

EMBEDMENT DIMENSIONS			
PIPE DIAMETER (INCHES)	KIND OF PIPE	EXTERNAL DIAMETER Bc (INCHES)	TRENCH WIDTH Bd (INCHES)
6	PVC WATER	6.90	24
6	DI WATER	6.90	24
8	PVC WATER	9.05	25
8	DI WATER	9.05	25
8	PVC	8.40	25
12	PVC WATER	13.20	29
12	DI WATER	13.20	29
12	PVC	12.40	29
16	DI WATER	17.40	33
16	PVC WATER	17.40	33
18	DI WATER	19.50	36
18	PVC WATER	19.50	36
20	DI WATER	21.60	38
20	PVC WATER	21.60	38
24	PVC WATER	25.80	42
24	DI WATER	25.80	42
24	RCCP WATER	30.00	48
30	PVC WATER	32.00	48
30	DI WATER	32.00	48
30	RCCP WATER	32.00	48

NOTES:

1. RCCP = REINFORCED CONCRETE CYLINDER PIPE.
2. EMBEDMENT DIMENSION FOR HDPE PIPE SHALL BE IN ACCORDANCE WITH MANUFACTURE'S RECOMMENDATIONS.

**SPRINGS HILL SPECIAL UTILITY DISTRICT**

**EMBEDMENT  
SHT 3 OF 3**

DATE:  
08/12/2010

REVISIONS:

STANDARD NO.  
WA-41

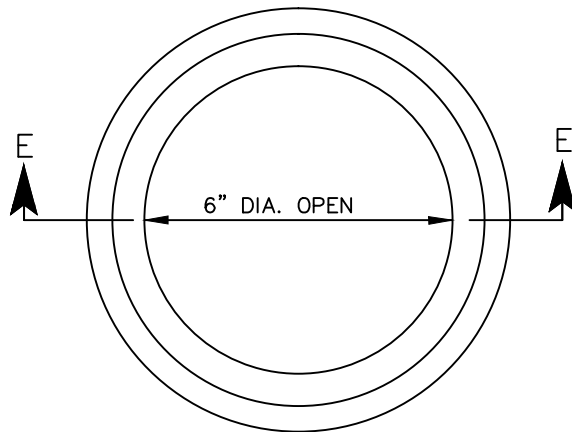

PLAN VIEW

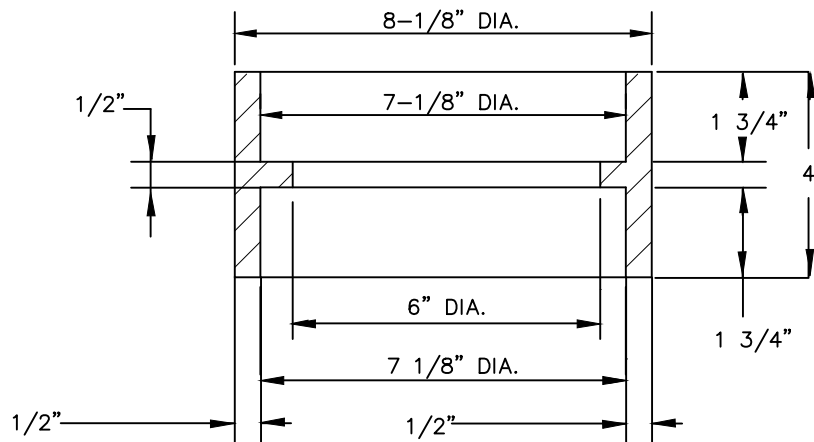

SECTION E-E

NOTES:

1. MATERIAL SHALL BE GRAY CAST IRON, ASTM A48, GRADE 30B.
2. THE MANUFACTURER'S IDENTIFICATION, CASTING NUMBER, AND THE COUNTRY WHERE CAST, SHALL BE DISTINCTLY CAST ONTO EACH LID.
3. DRAFT AND SHRINKAGE ALLOWANCE SHALL BE IN ACCORDANCE WITH NORMAL FOUNDRY PRACTICE.
4. FINISH BY REMOVING FINS AND FLASHING; PAINT WITH BLACK ASPHALT COATING,
5. WEIGHT: APPROXIMATELY 17 LBS.

**SPRINGS HILL SPECIAL UTILITY DISTRICT**

**VALVE BOX CASTING COLLAR  
(NOT IN PAVEMENT)**

DATE:  
07/26/2010

REVISIONS:

STANDARD NO.  
WA-42

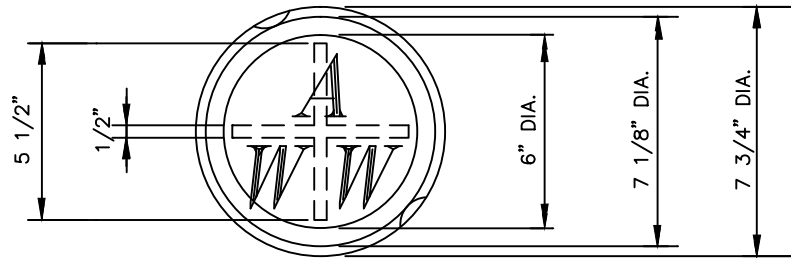

PLAN VIEW

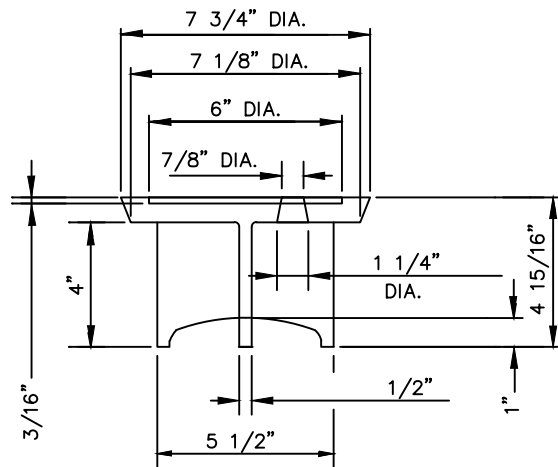

ELEVATION

NOTES:

1. MATERIAL SHALL BE GRAY CAST IRON, ASTM A48, GRADE 30B.
2. TYPICAL FILLET IS 3/16" RADIUS.
3. LETTERING SHALL BE 1 1/2" HEIGHT AND LOCATED AS SHOWN.
4. THIS LID REQUIRES TWO (2) PICK SLOTS.
5. THE MANUFACTURER'S IDENTIFICATION, CASTING NUMBER, AND THE COUNTRY WHERE CAST, SHALL BE DISTINCTLY CAST ONTO EACH LID.
6. DRAFT AND SHRINKAGE ALLOWANCE SHALL BE IN ACCORDANCE WITH NORMAL FOUNDRY PRACTICE.
7. FINISH BY REMOVING FINS AND FLASHING; PAINT WITH BLACK ASPHALT COATING,
8. WEIGHT: APPROXIMATELY 13 LBS.

**SPRINGS HILL SPECIAL UTILITY DISTRICT**

**VALVE BOX CASTING LID  
(IN PAVEMENT)**

DATE:  
07/26/2010

REVISIONS:

STANDARD NO.  
WA-43

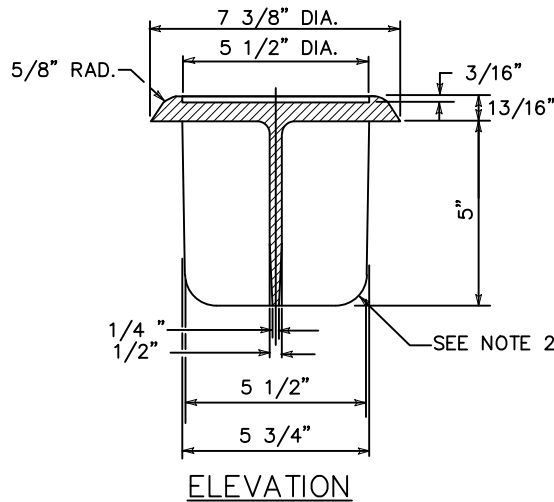
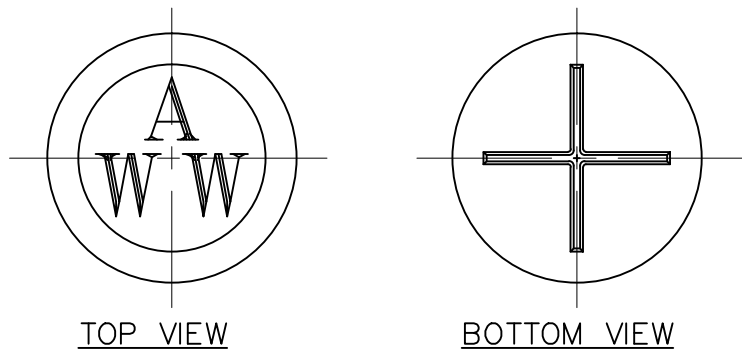

NOTES:

1. MATERIAL SHALL BE GRAY CAST IRON, ASTM A48, GRADE 30B.
2. TYPICAL FILLET IS 3/16" RADIUS.
3. LETTERING SHALL BE 1 1/2" HEIGHT AND LOCATED AS SHOWN.
4. THIS LID FITS INSIDE 6" I.D. PIPE.
5. THE MANUFACTURER'S IDENTIFICATION, CASTING NUMBER, AND THE COUNTRY WHERE CAST, SHALL BE DISTINCTLY CAST ONTO EACH LID.
6. DRAFT AND SHRINKAGE ALLOWANCE SHALL BE IN ACCORDANCE WITH NORMAL FOUNDRY PRACTICE.
7. FINISH BY REMOVING FINS AND FLASHING; PAINT WITH BLACK ASPHALT COATING,
8. WEIGHT: APPROXIMATELY 13 LBS.

<b>SPRINGS HILL SPECIAL UTILITY DISTRICT</b>	<b>VALVE BOX CASTING LID (NOT IN PAVEMENT)</b>	
	DATE: 07/26/2010	REVISIONS: STANDARD NO. WA-44

7/16" DIA., 4 HOLES CENTERED AND EQUALLY SPACED ON FLANGE

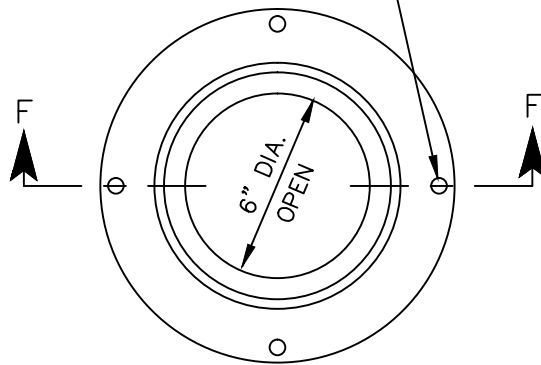

PLAN VIEW

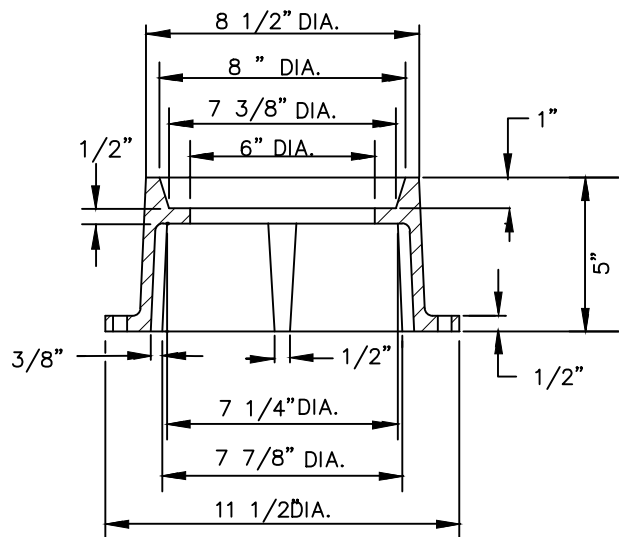

SECTION F-F

NOTES:

1. MATERIAL SHALL BE GRAY CAST IRON, ASTM A48, GRADE 30B.
2. THE MANUFACTURER'S IDENTIFICATION, CASTING NUMBER, AND THE COUNTRY WHERE CAST, SHALL BE DISTINCTLY CAST ONTO EACH LID.
3. DRAFT AND SHRINKAGE ALLOWANCE SHALL BE IN ACCORDANCE WITH NORMAL FOUNDRY PRACTICE.
4. FINISH BY REMOVING FINS AND FLASHING; PAINT WITH BLACK ASPHALT COATING,
5. WEIGHT: APPROXIMATELY 23 LBS.

**SPRINGS HILL SPECIAL UTILITY DISTRICT**

**VALVE BOX CASTING PAVING RING**

DATE:  
07/26/2010

REVISIONS:

STANDARD NO.  
WA-45

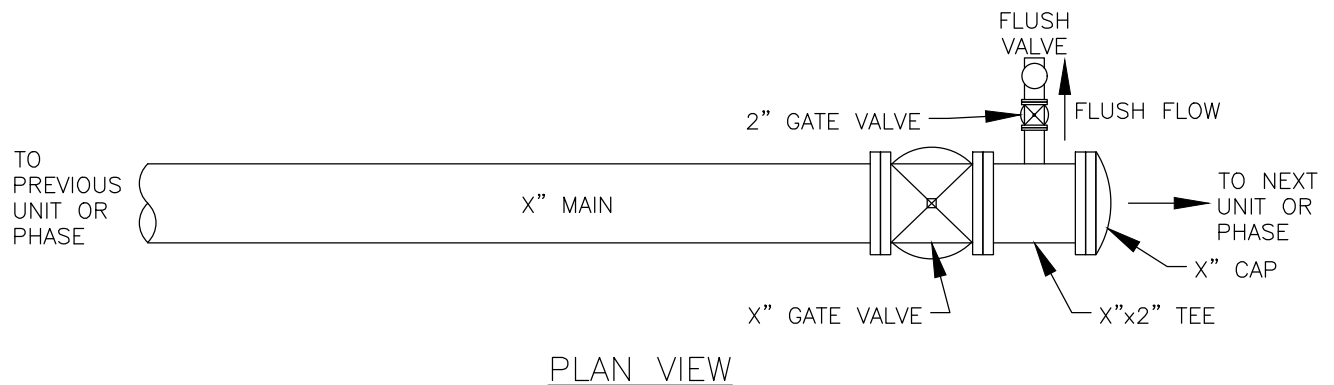
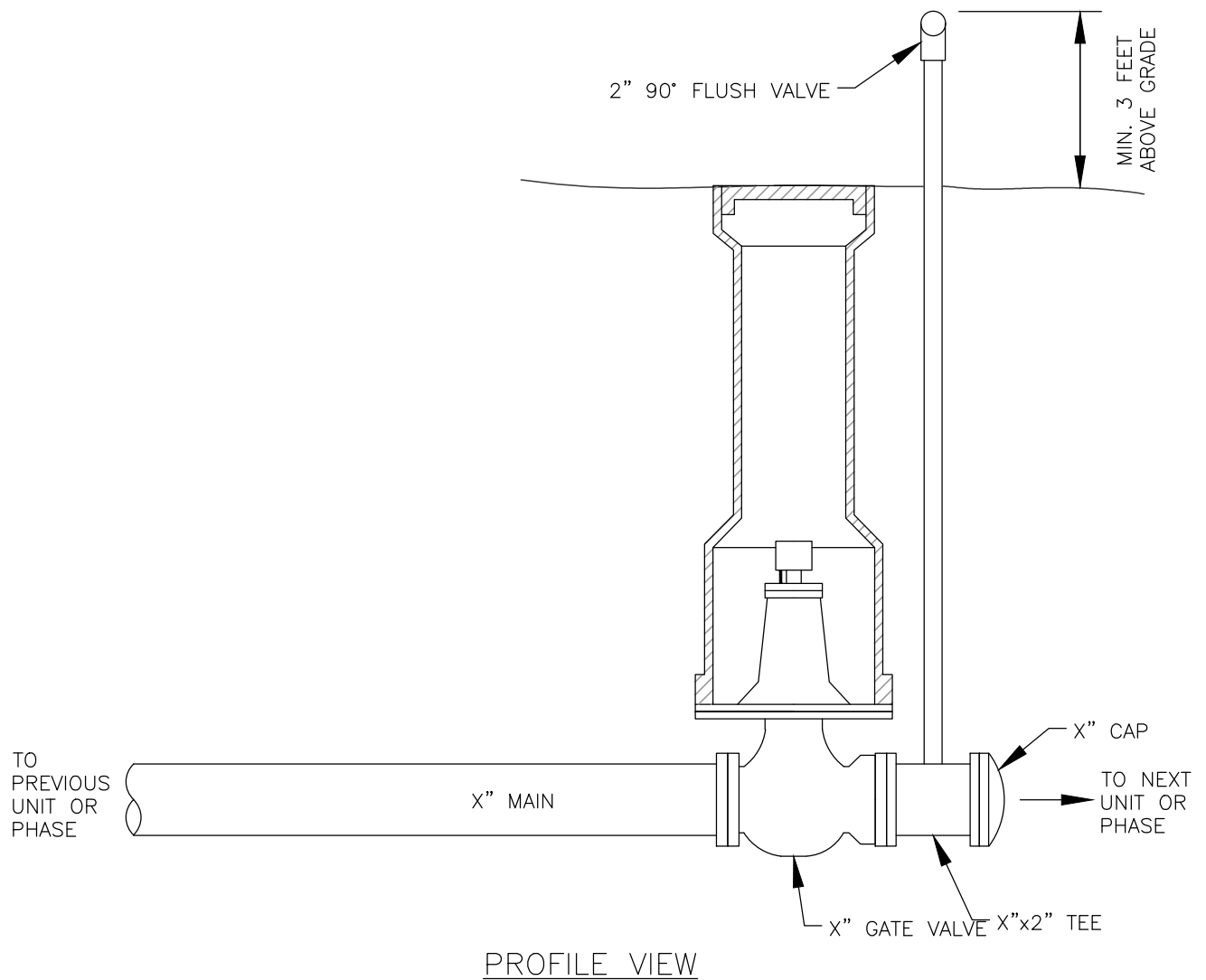

**NOTE:**

1. BURIED PIPING, FITTINGS, AND FITTINGS JOINTS SHALL BE WRAPPED IN POLYWRAP.
2. THE EARTHBEARING SURFACE SHALL BE THE UNDISTURBED TRENCH WALL.
3. ALL PIPE JOINTS SHALL BE KEPT FREE FROM CONCRETE.
4. POLYWRAP SHALL BE SECURED WITH A MINIMUM OF THREE CIRCUMFERENTIAL TURNS OF POLY TAPE.

NOT TO SCALE

**SPRINGS HILL SPECIAL UTILITY DISTRICT**

**TEMPORARY BLOW OFF  
8-INCH OR SMALLER**

DATE:  
10/21/2021

REVISIONS:

STANDARD NO.  
WA-46

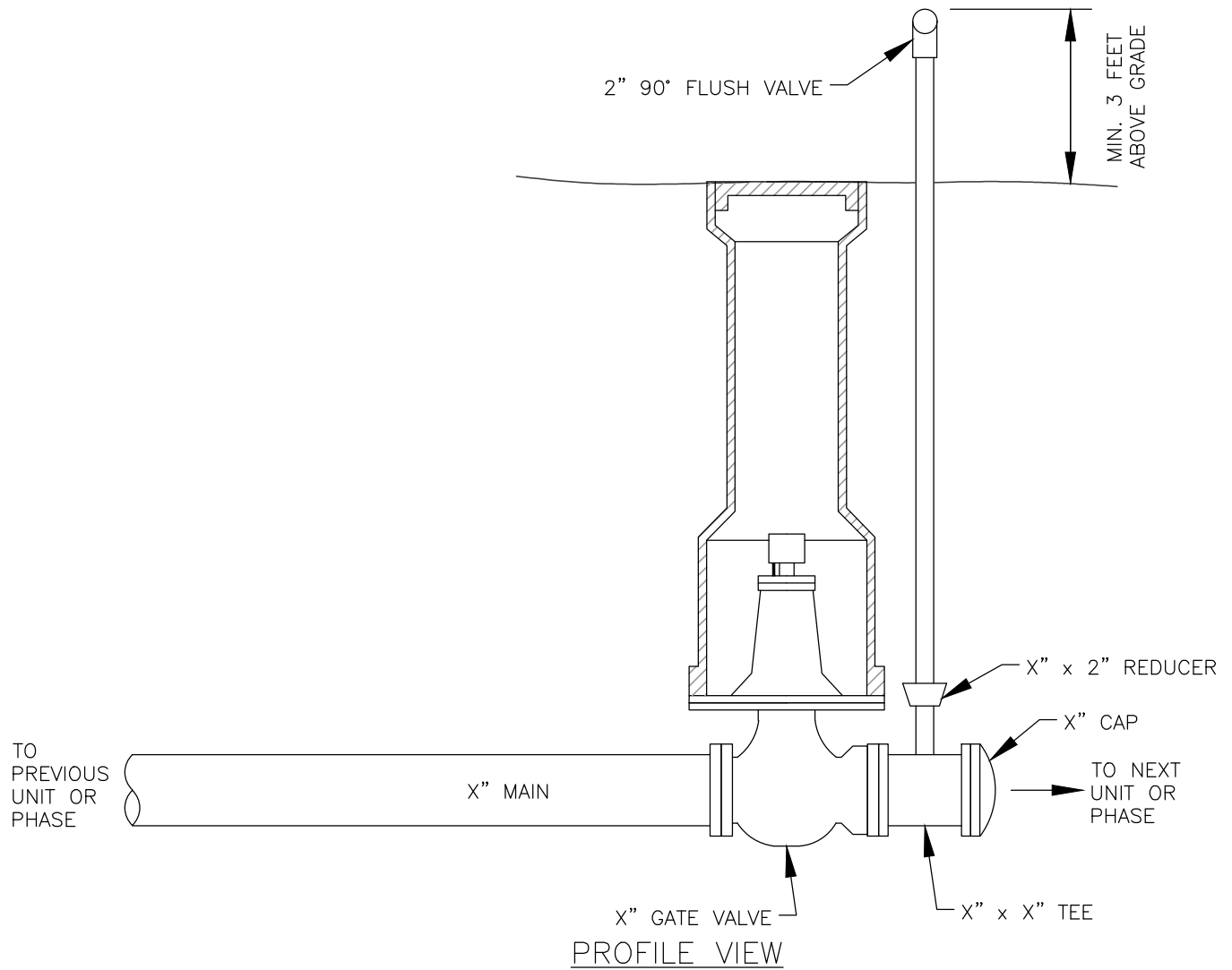

PROFILE VIEW

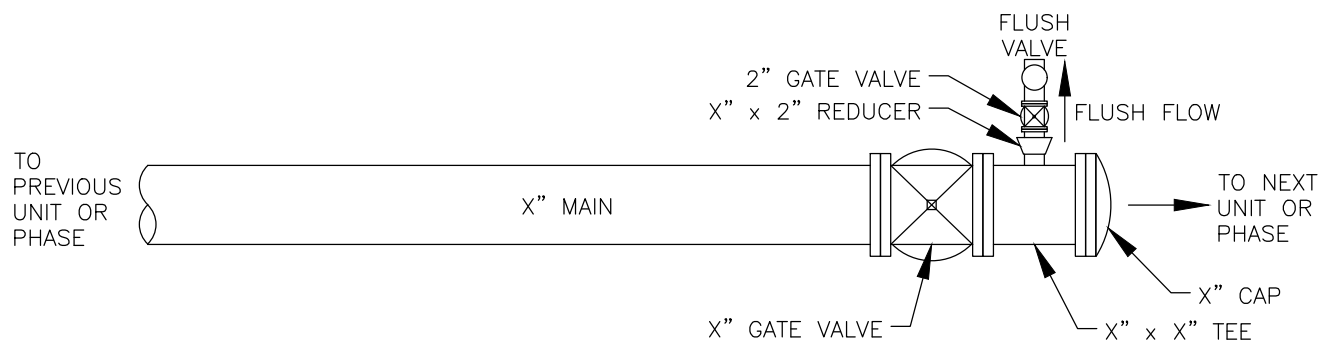

PLAN VIEW

NOTE:

1. BURIED PIPING, FITTINGS, AND FITTINGS JOINTS SHALL BE WRAPPED IN POLYWRAP.
2. THE EARTHBEARING SURFACE SHALL BE THE UNDISTURBED TRENCH WALL.
3. ALL PIPE JOINTS SHALL BE KEPT FREE FROM CONCRETE.
4. POLYWRAP SHALL BE SECURED WITH A MINIMUM OF THREE CIRCUMFERENTIAL TURNS OF POLY TAPE.

NOT TO SCALE

**SPRINGS HILL SPECIAL UTILITY DISTRICT**

**TEMPORARY BLOW OFF  
12-INCH OR LARGER**

DATE:  
10/21/2021

REVISIONS:

STANDARD NO.  
WA-47